



ASSEMBLY INSTRUCTION

VALDA QUEEN BED

ITEM CODE 85107

Imported by Amart Furniture Pty Ltd, Qld, Brisbane Australia.

For any assistance with assembly or for missing parts please phone
Amart Furniture Road, Customer Service Free call 1800 351 084

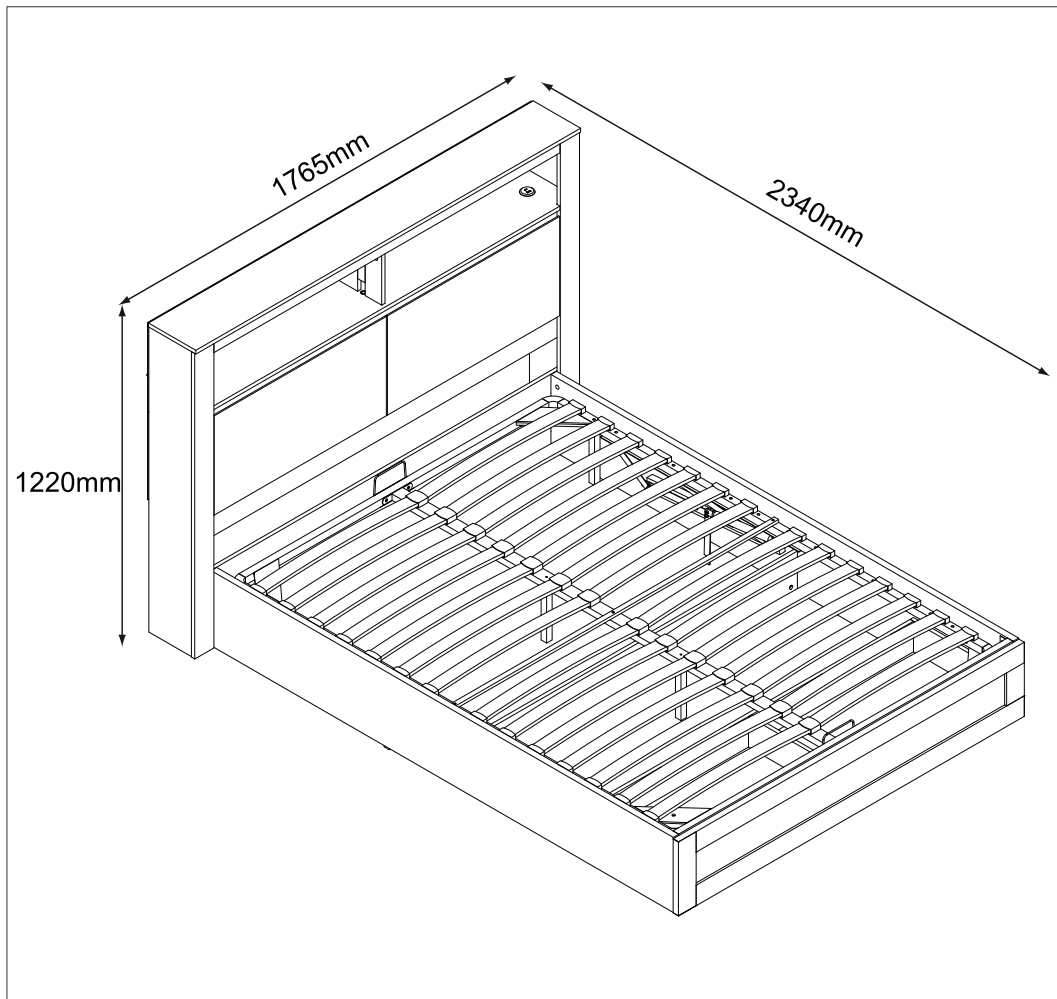

Imported by Amart Furniture Pty Ltd, Qld, Brisbane Australia.

For any assistance with assembly or for missing parts please phone
Amart Furniture Road, Customer Service Free call 1800 351 084

PRE-ASSEMBLY PREPARATION

Before you start:

1. Choose a clean, level, spacious assembly area. Avoid hard surfaces that may damage the product.
2. Take care when lifting. Product should be assembled as near as possible to the point of use.
3. Ensure that you have all required contents for complete assembly.
4. Always read the assembly instructions carefully before beginning assembly.
5. Keep all hardware parts and packaging out of reach of small children.
6. Do not over tighten the screws and bolts as this may damage the threads.

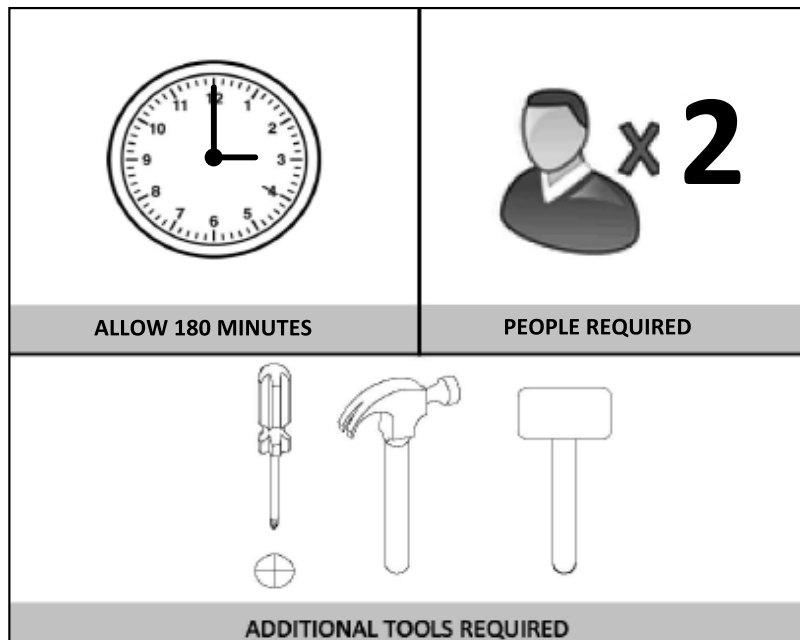

WARNING



Do not allow children to play on this mechanised furniture or operate the mechanism. This lift bed base raises at the rear - do not place objects under it and make sure area is clear of obstructions including pets and small children.

Ensure that the mattress and lift mechanism has been returned to the lowered position before lying or sitting on the mattress. Always ensure that your body is clear of the lift mechanism when lifting and lowering the mechanism

PARTS LIST

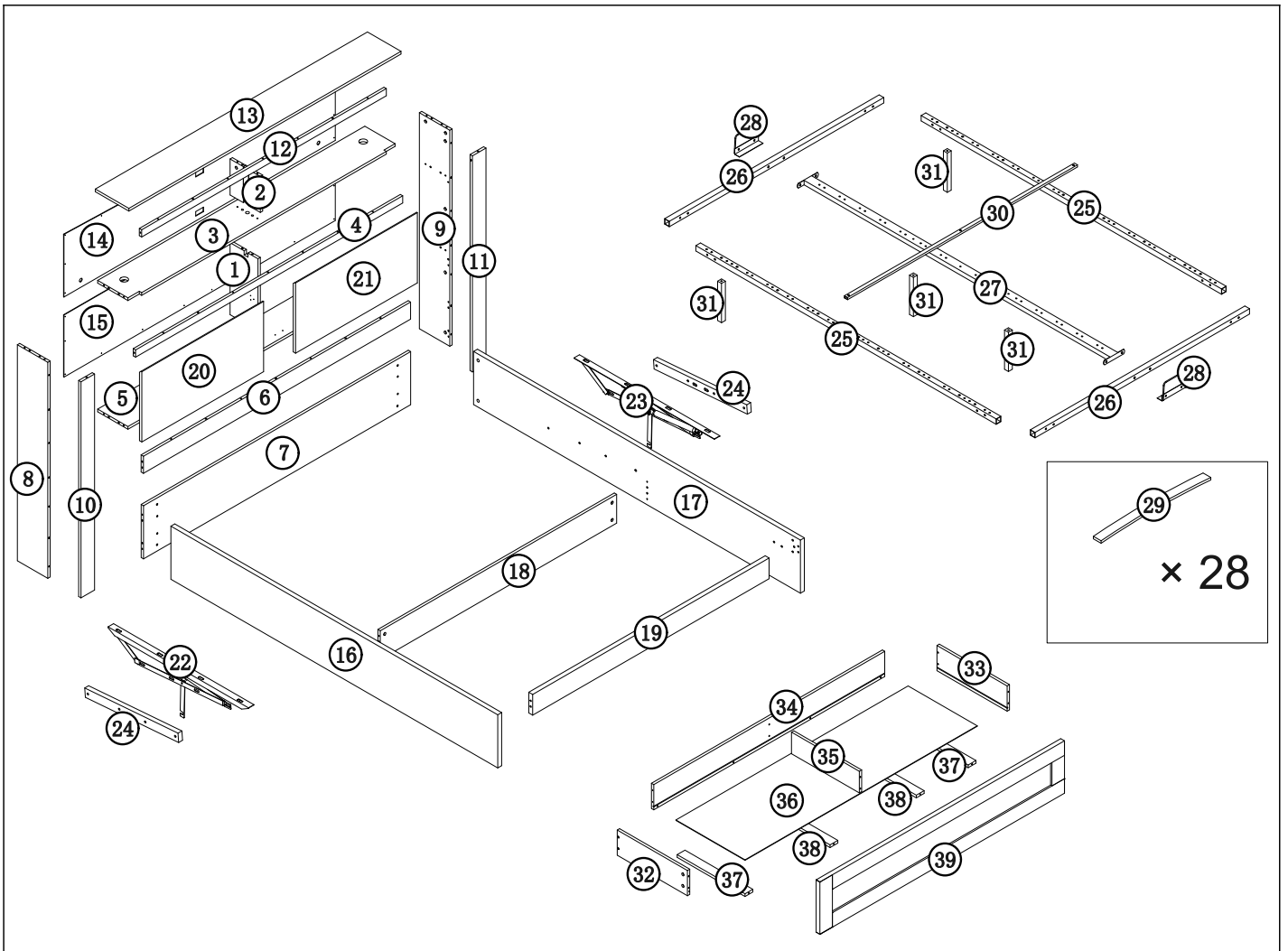













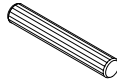

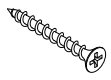













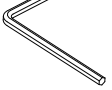



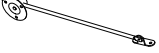

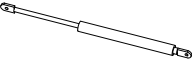
1	Support Panel
2	Support Panel
3	Shelf
4	Rail
5	Bottom Panel
6	Back Panel
7	Back Panel
8	Side Panel
9	Side Panel
10	Rail
11	Rail
12	Rail
13	Top Panel

14	Back Panel
15	Back Panel
16	Side Panel
17	Side Panel
18	Connect Panel
19	Connect Panel
20	Door Panel
21	Door Panel
22	Metal Parts
23	Metal Parts
24	Support Panel
25	Metal Parts
26	Metal Parts

PARTS LIST

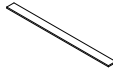
27	Metal Parts
28	Handle
29	Slat
30	Metal Parts
31	Leg
32	Drawer Side Panel
33	Drawer Side Panel

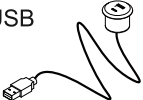
34	Drawer Back Panel
35	Support Panel
36	Drawer Base
37	Support Panel
38	Support Panel
39	Drawer Front

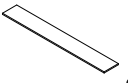
A cam pin  M7×39mm 52×A	B cam lock  52×B	C dowel  M8×30mm 51×C	D dowel  M8×50mm 4×D	E screw  M3.5×14mm 38×E	F screw  M5×40mm 14×F
G screw  M5×50mm 8×G	H screw  M3×16mm 28×H	I Washer  M6mm 23×I	J Washer  M6mm 23×J	K Washer  M8mm 44×K	L Washer  M8mm 44×L
M bolt  M6×16mm 20×M	N bolt  M8×45mm 40×N	O filler  1×O	P bolt  M6×25mm 3×P	Q bolt  M8×65mm 4×Q	R nut  M12×20mm 4×R
S allen key  4mm 1×S	T allen key  5mm 1×T	U angle iron  2×U	V hexagonal nuts  4×V	W angle iron  6×W	X hinge  4×X
Y lift  2×Y	Z hexagonal nuts  28×Z	AA lift  2×AA	BB wrench  1×BB	CC connector  4×CC	DD connector  28×DD
EE connector  14×EE	FF wheel  6×FF	GG foot pad  2×GG	HH control switch  1×HH	II cable box  1×II	JJ USB  2×JJ
KK connecting wire  1×KK	LL foot pad  6×LL				

STEP1: Insert dowel (C) to panel (1&2&3).
Fix cam pin (A) to panel (3).

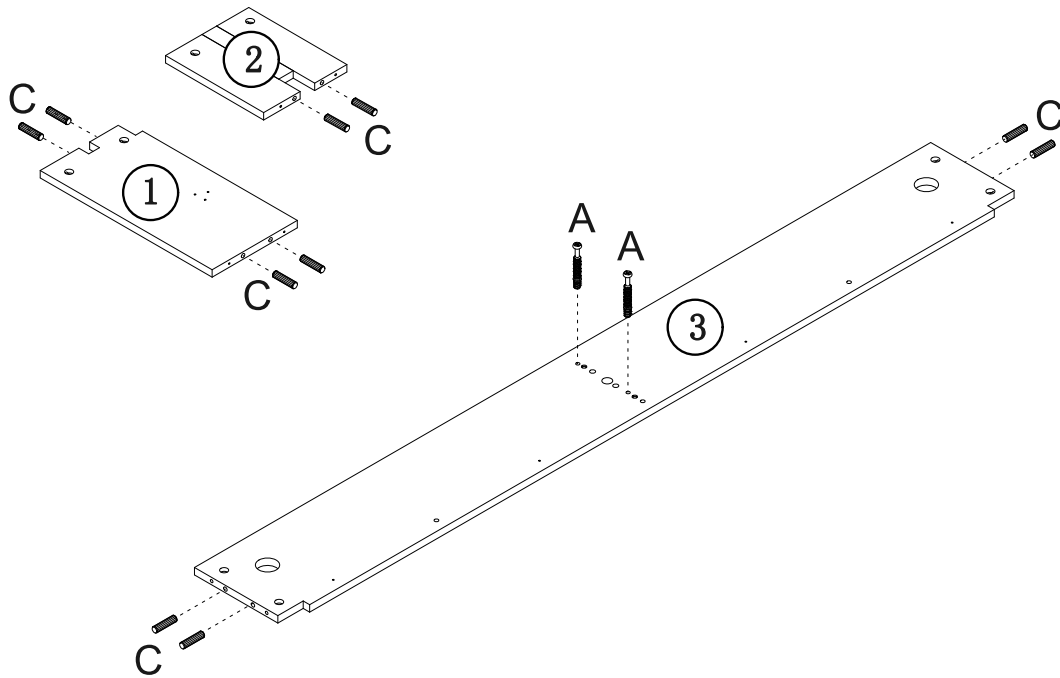

STEP2: Insert dowel (C) to panel (4&5).
Fix cam pin (A) to panel (5).

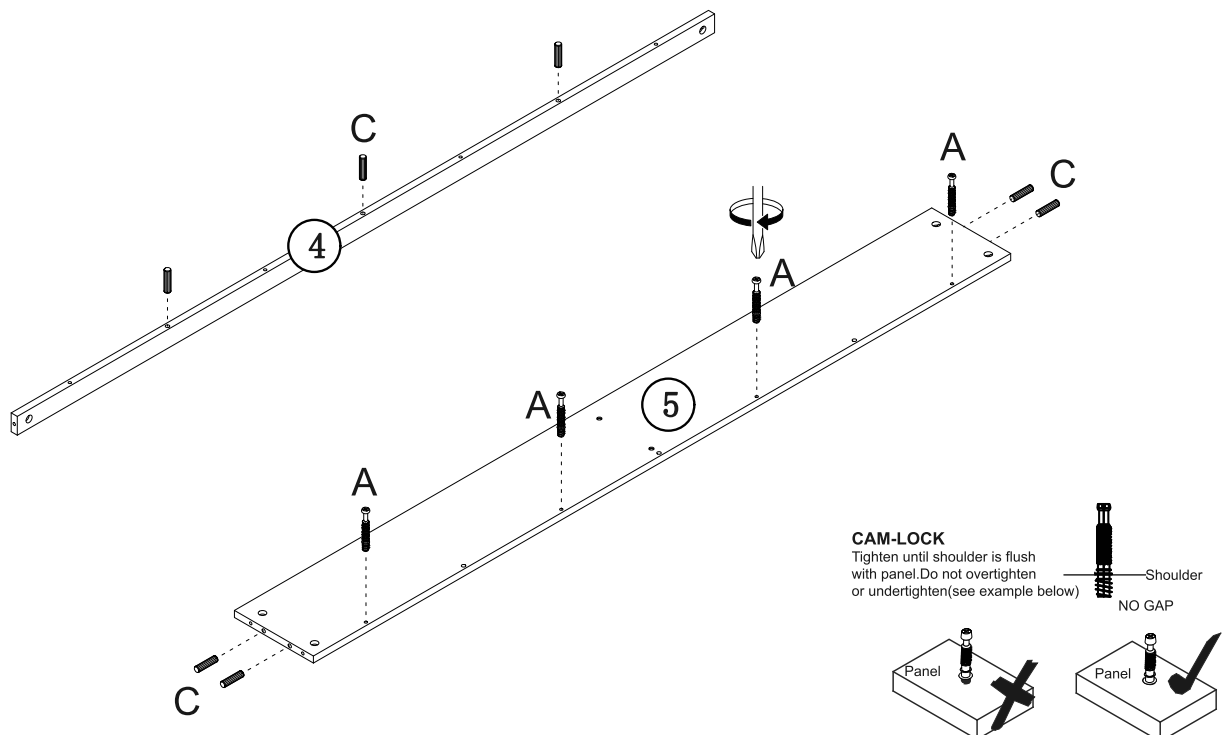

STEP3: Insert dowel (C) to panel (6&7).

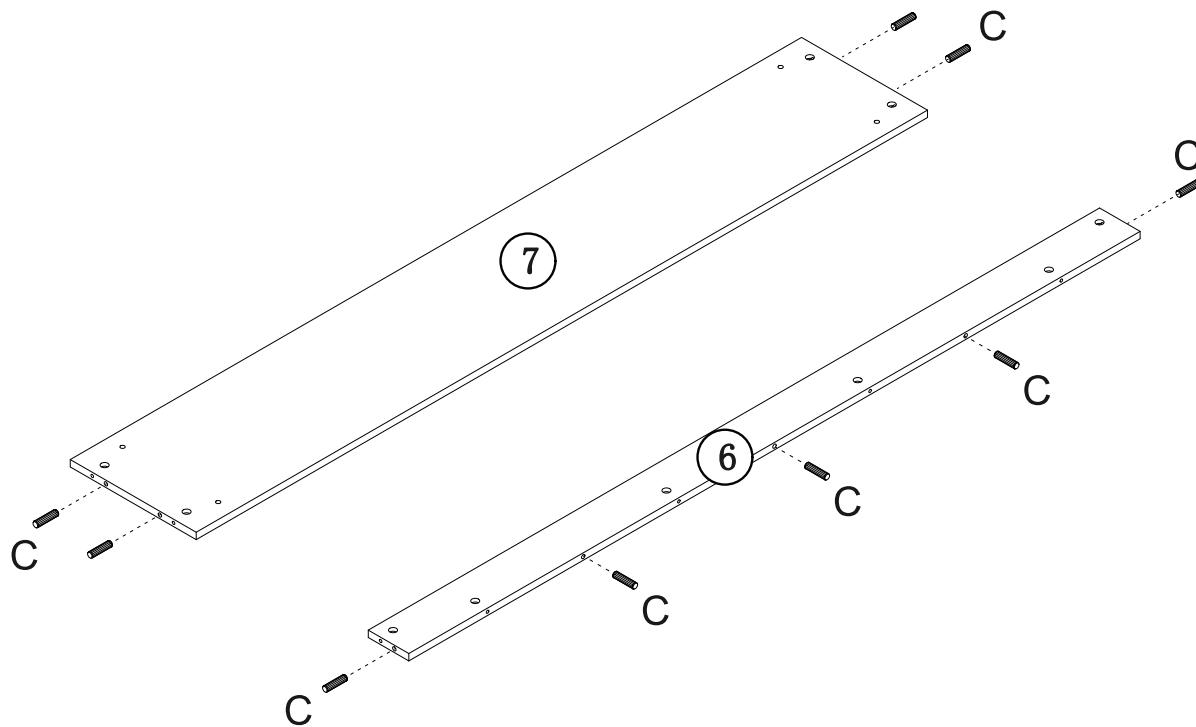

STEP4: Attach panel (2) to panel (3) with screws (F).

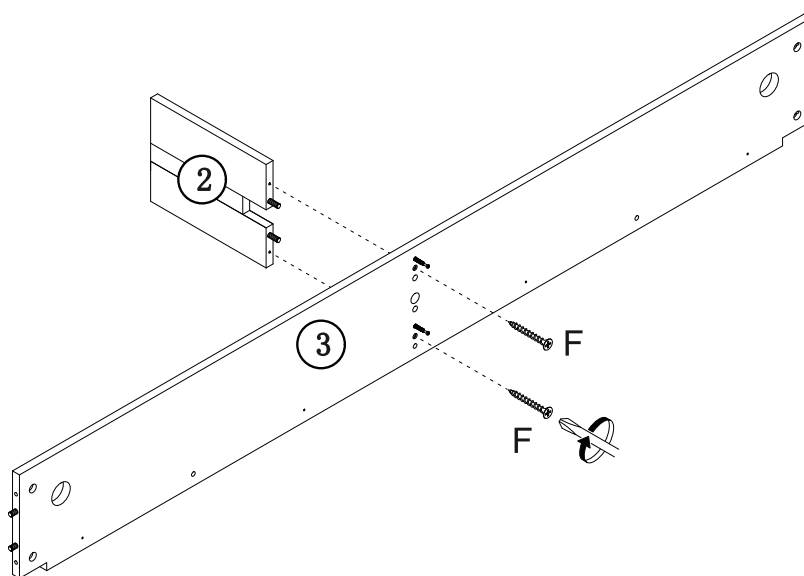

STEP5: Attach panel (4) to panel (3) with screws (G).

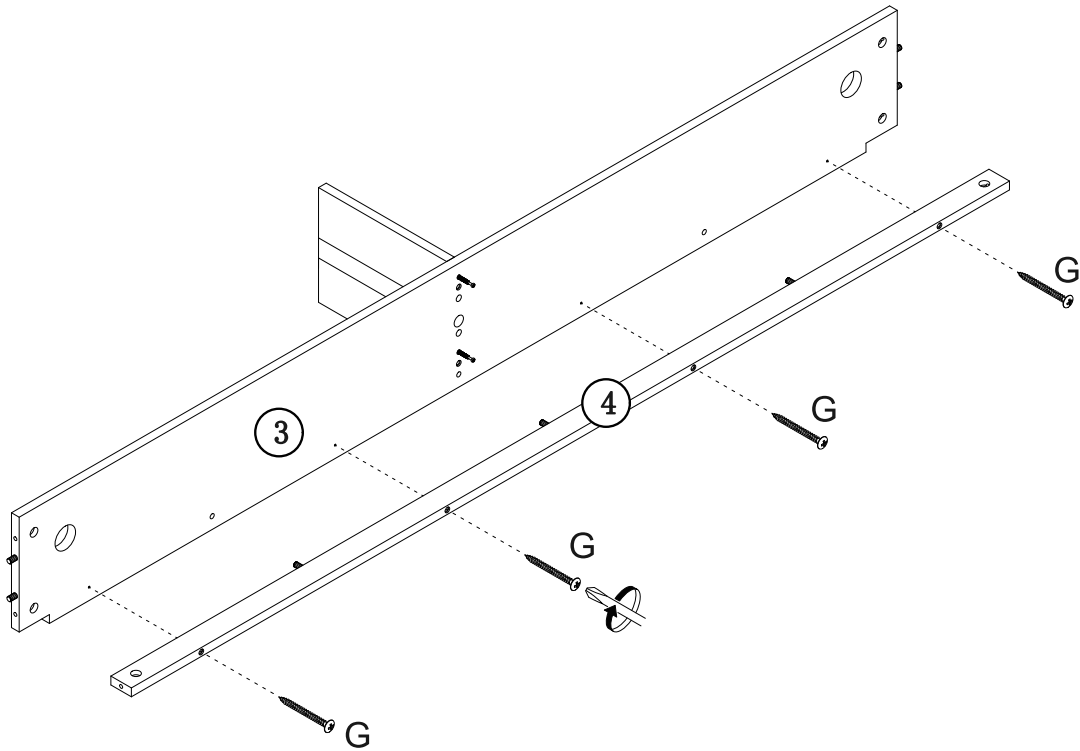

STEP6: Attach panel (1) to panel (3) with cam lock (B).

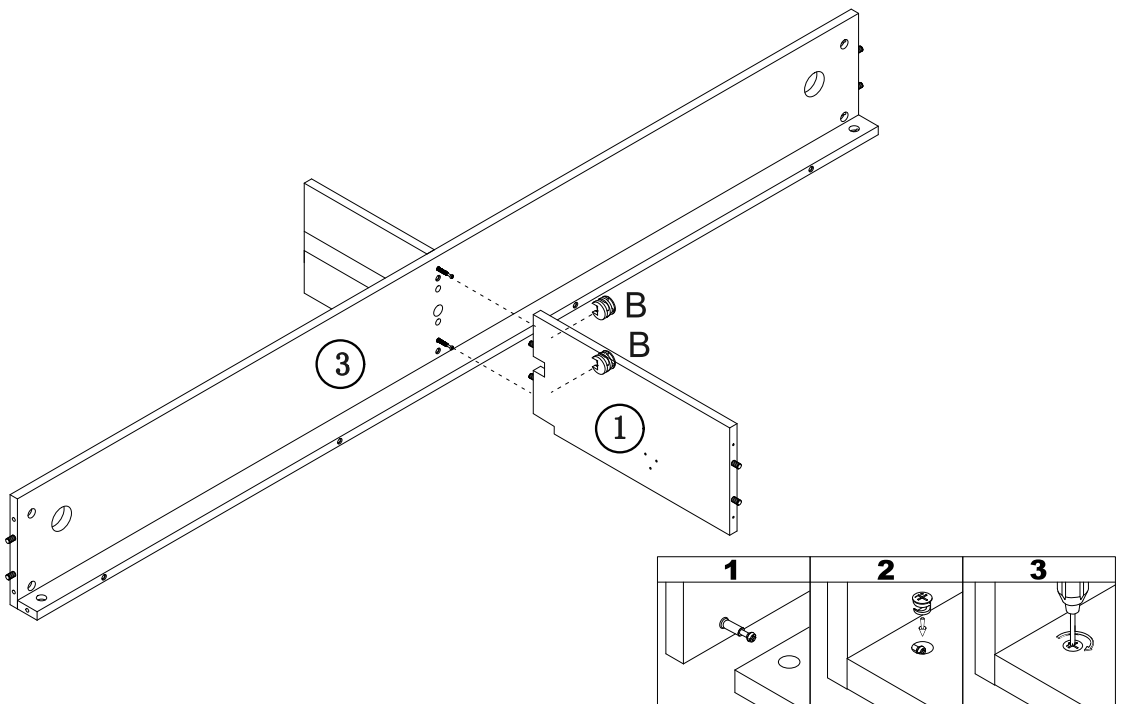

STEP7: Attach panel (5) to panel (1) with screws (F).

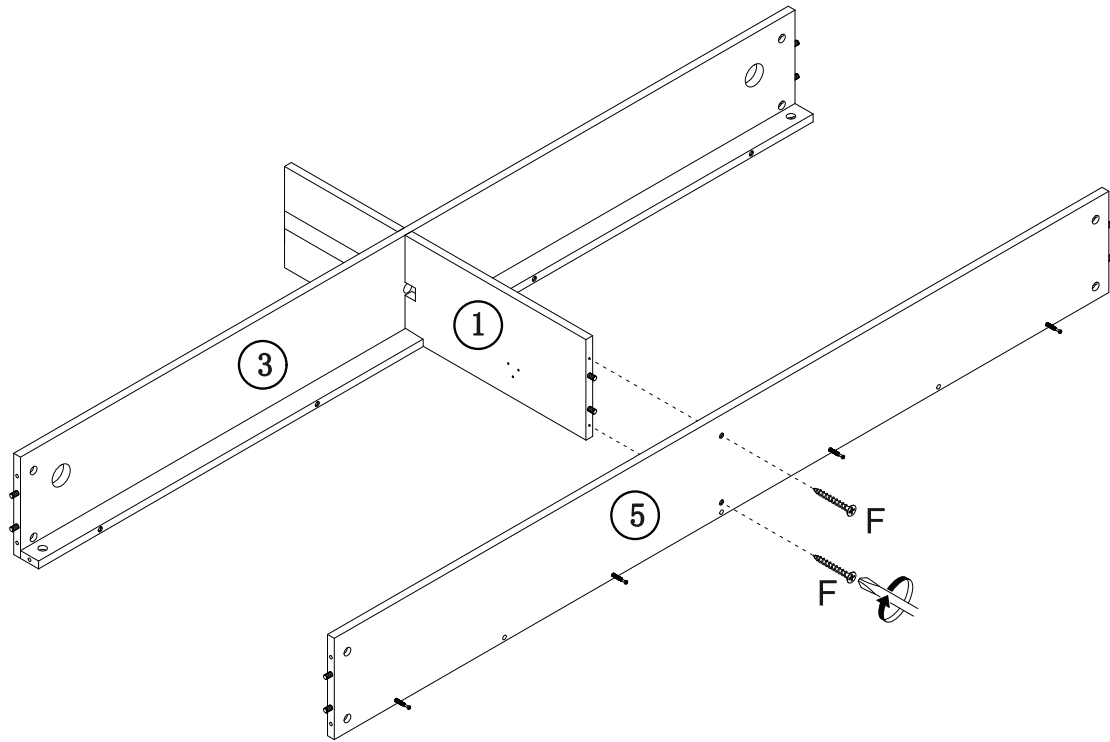

STEP8: Attach panel (6) to panel (5) with cam lock (B).

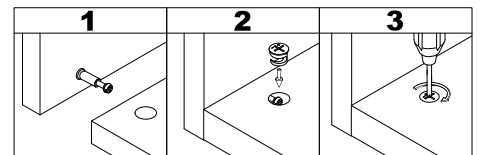
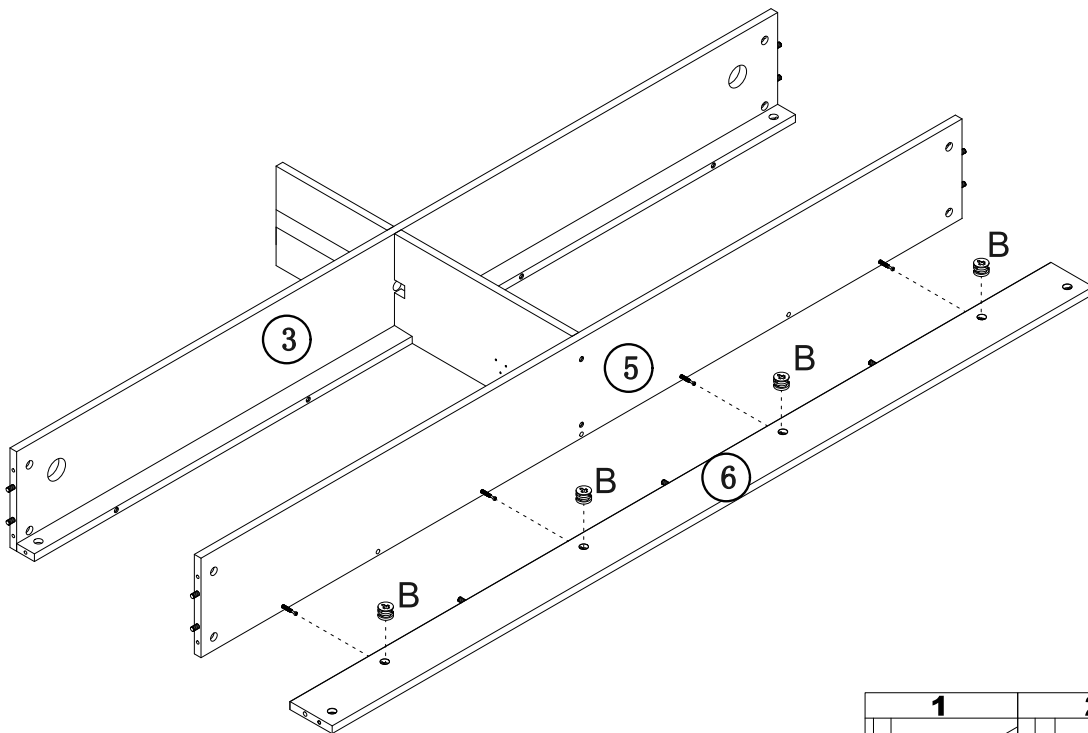

STEP9: Fix cam pin (A) to panel (8&9).

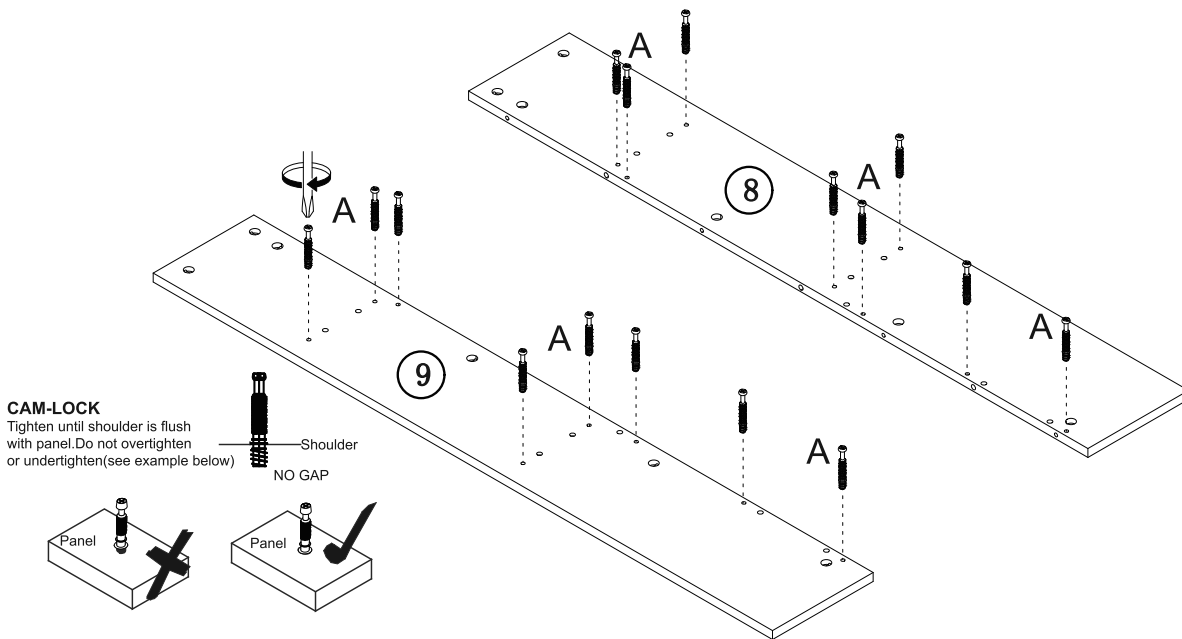

STEP10: Fix foot pad (GG) to panel (8&9).

Attach panel (8&9) to the body with cam lock (B).

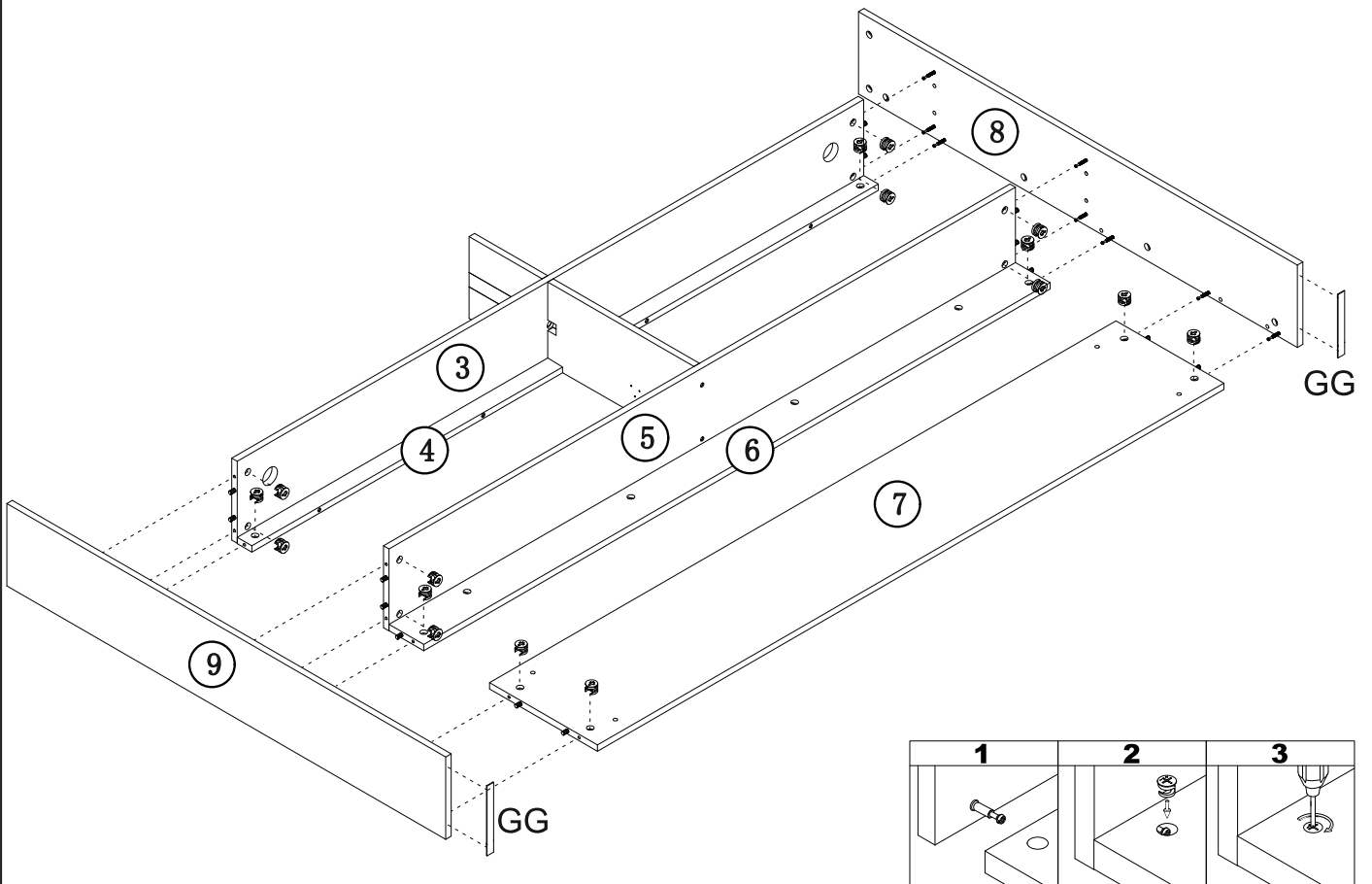

STEP11: Insert dowel (C) to panel (2&8&9).

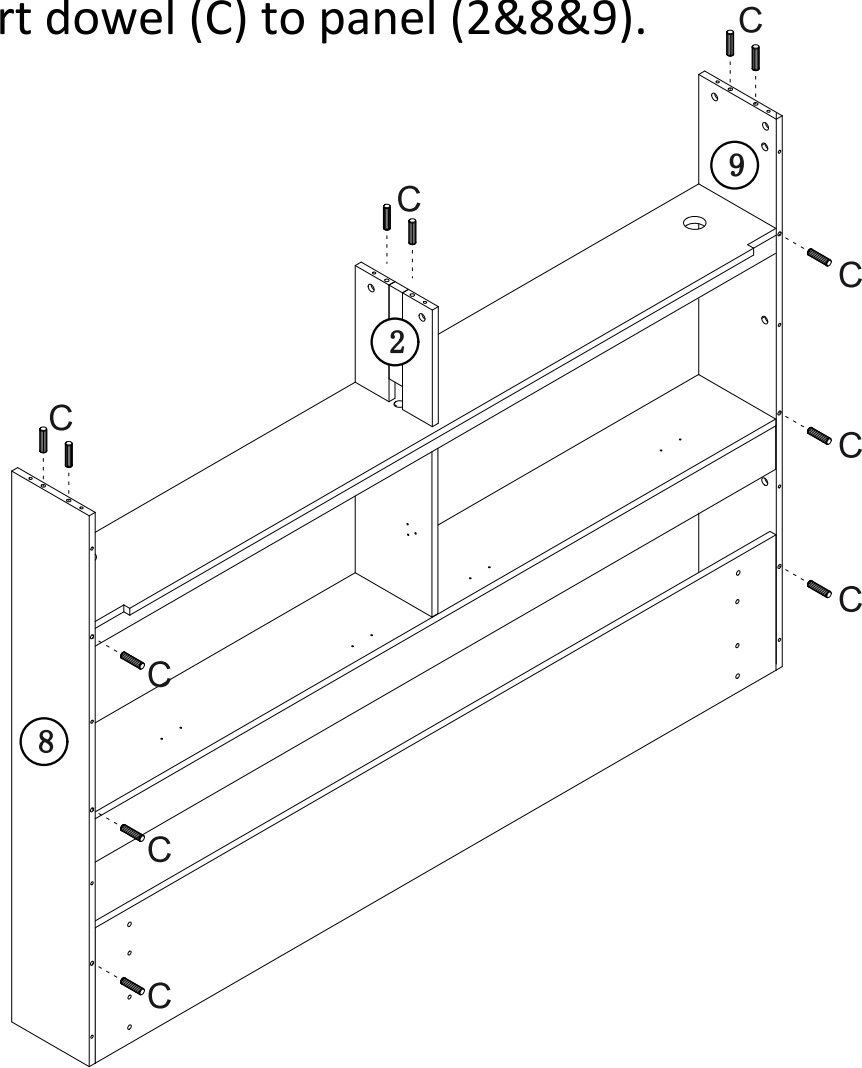

STEP12: Fix cam pin (A) and insert dowel (C) to panel (10&11).
Insert dowel (C) to panel (12).

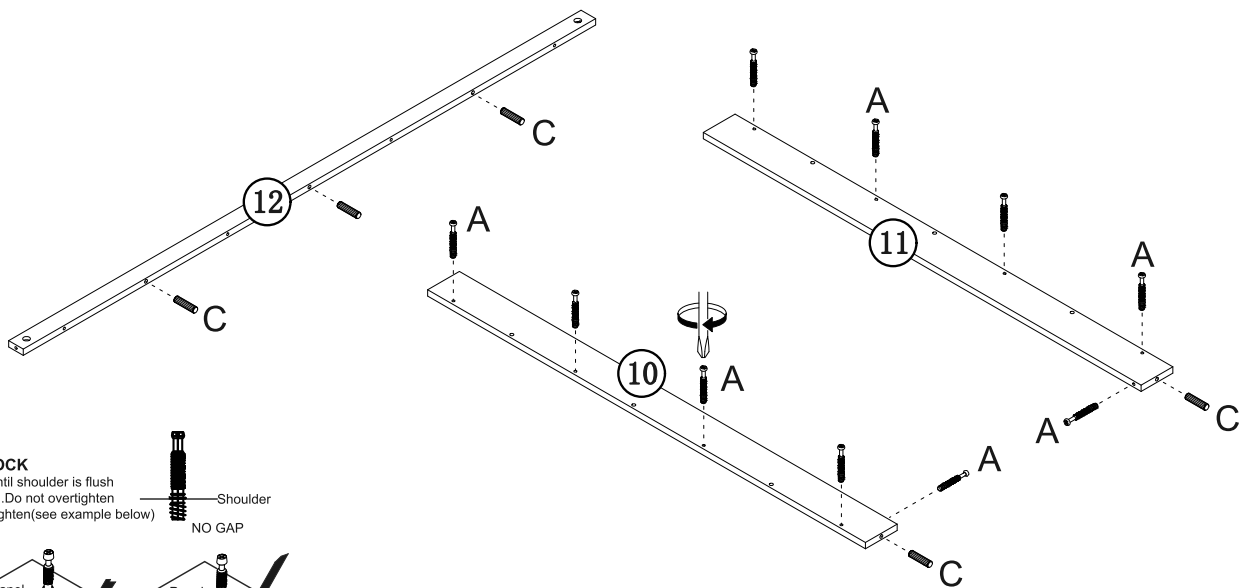

CAM-LOCK

Tighten until shoulder is flush with panel. Do not overtighten or undertighten (see example below)

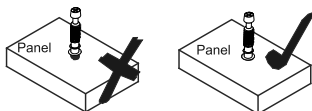
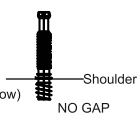

STEP13: Attach panel (12) to panel (10&11) with cam lock (B).

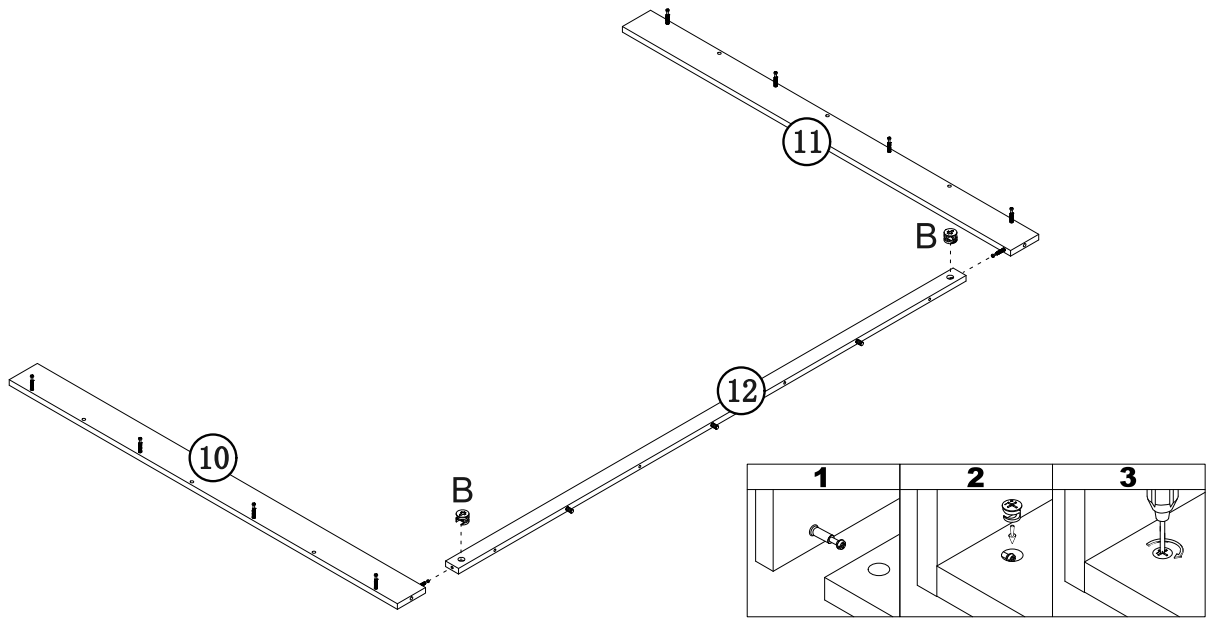

STEP14: Attach panel (10&11&12) to the body with cam lock (B).

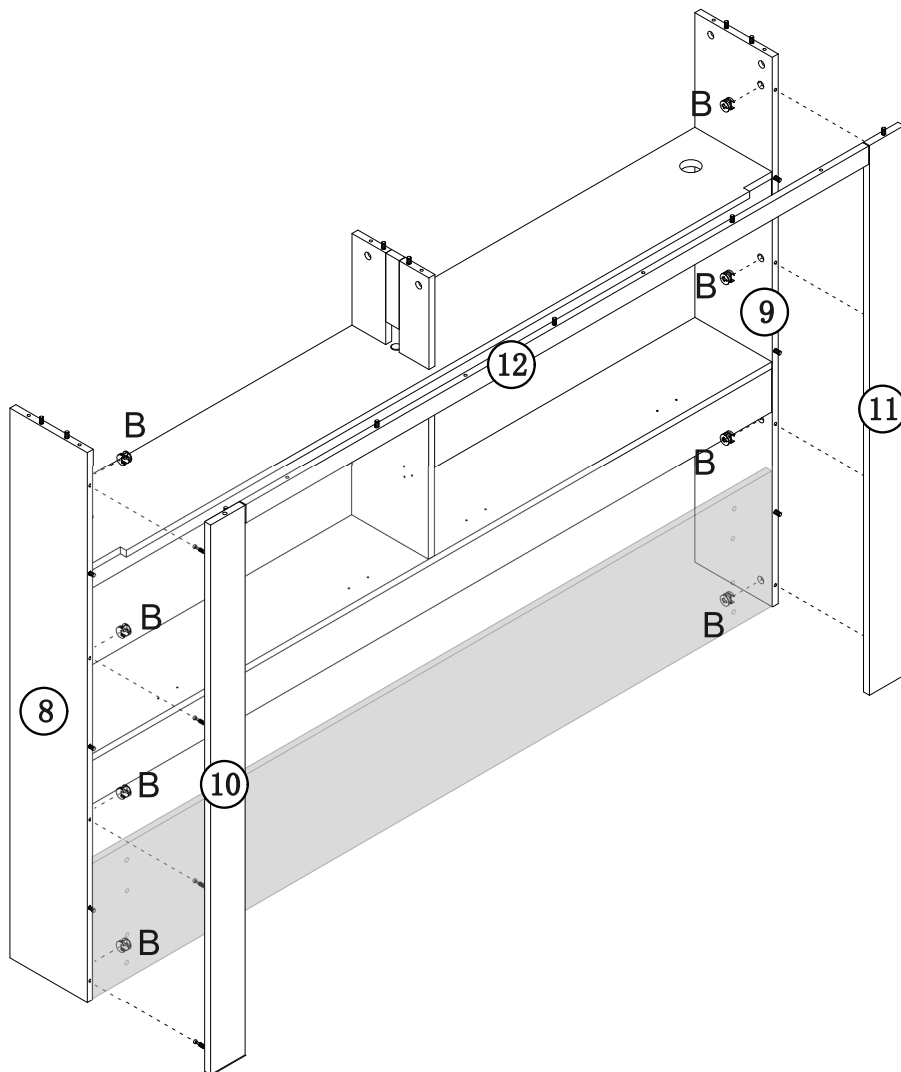

STEP15: Fix cam pin (A) to panel (13).

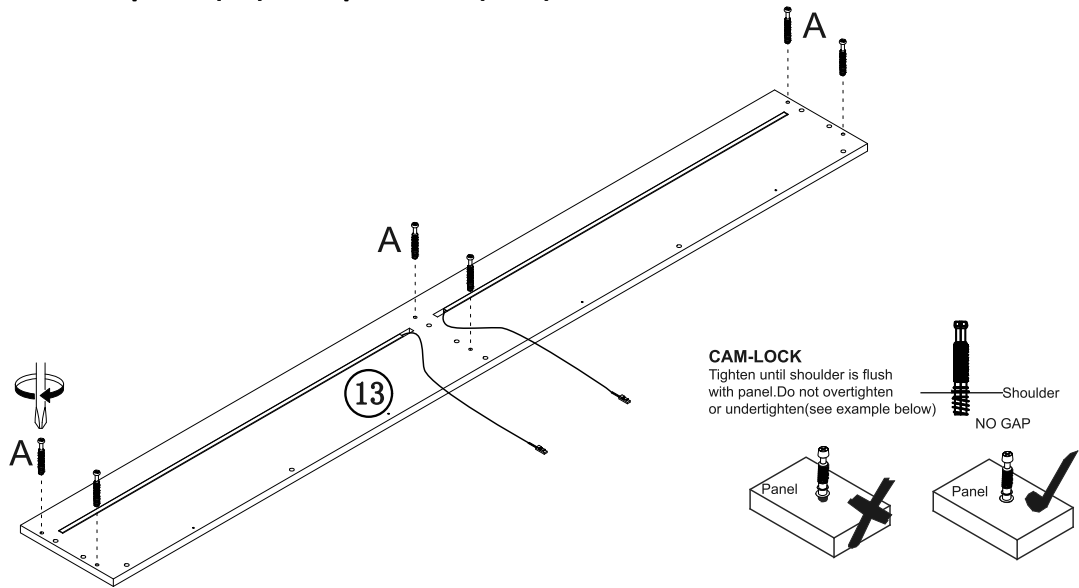

STEP16: Attach panel (13) to the body with cam lock (B) and screws (G).

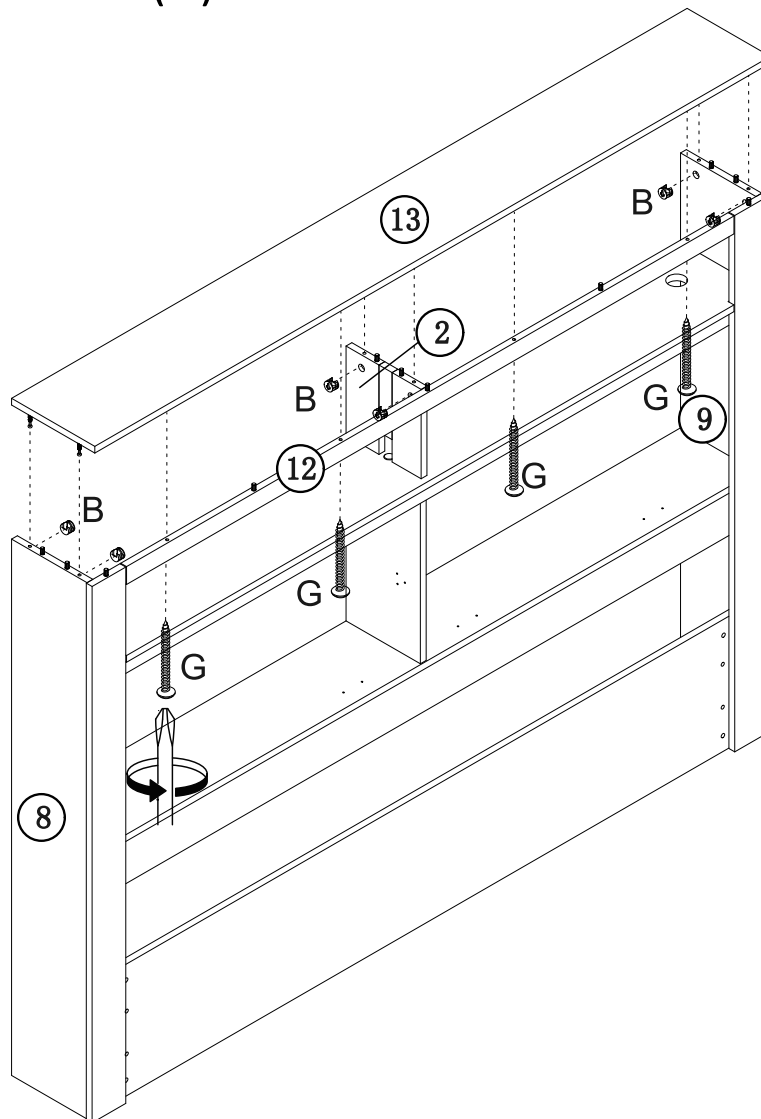

STEP17: Join panel (14&15) with filler (O).

Attach panel (14&15) to the body with screws (H).

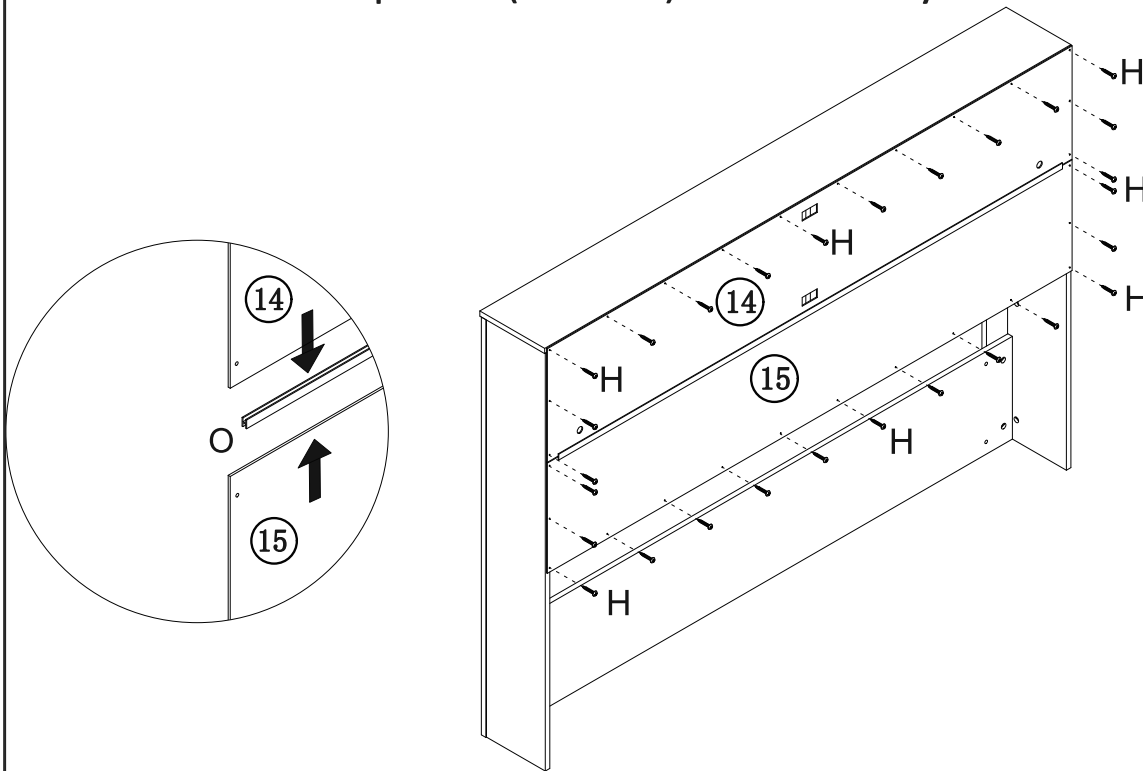

STEP18: Insert dowel (C) to panel (16&17&18).

Insert dowel (D) to panel (19).

Fix cam pin (A) to panel (16&17).

Fix foot pad (LL) to panel (16&17).

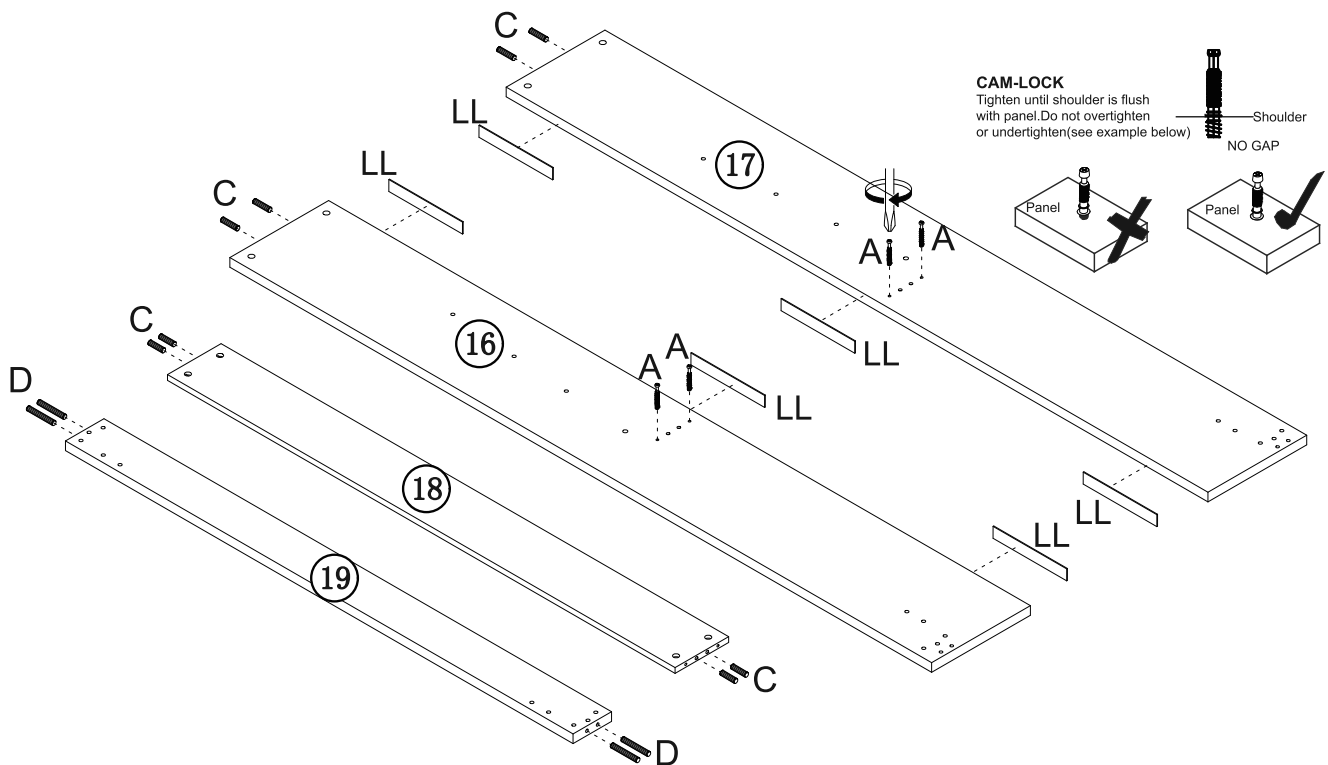

STEP19: Attach panel (18&19) to panel (16&17) with cam lock (B).

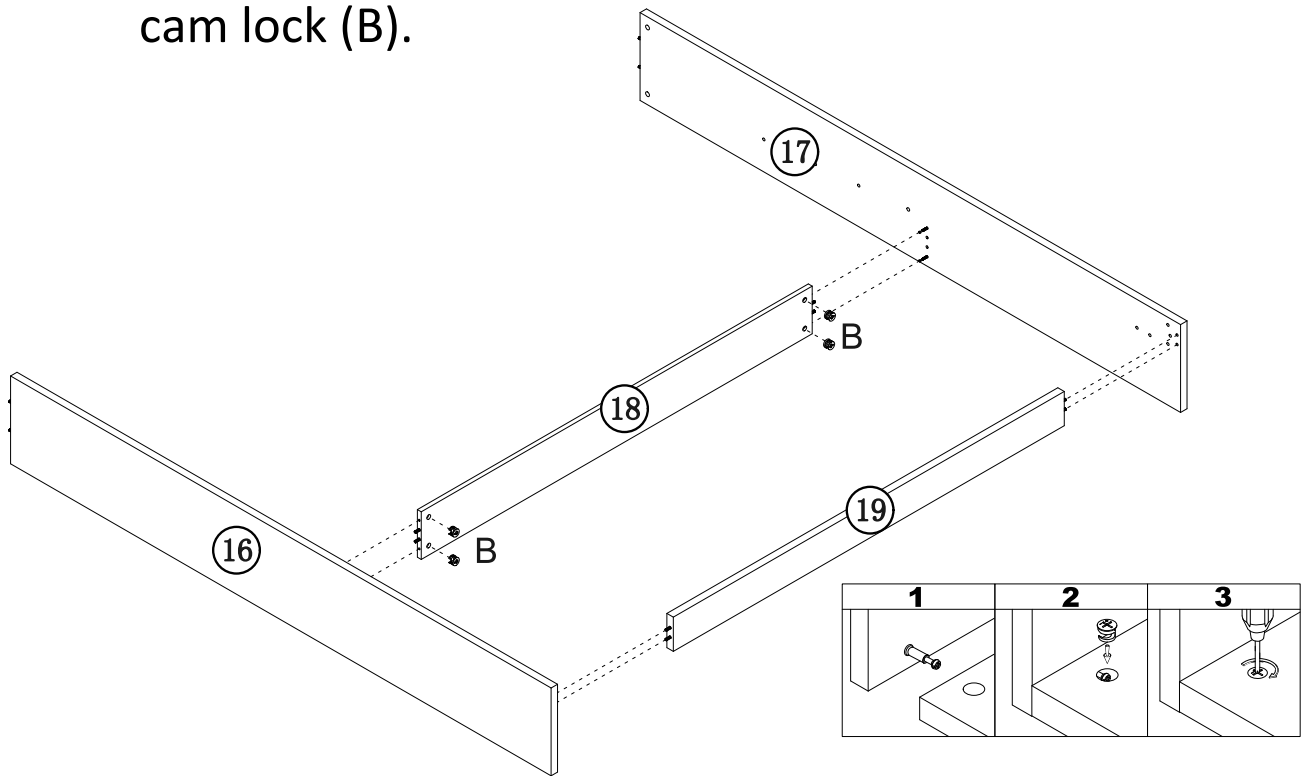

STEP20: Fix angle iron(U) to panel (16&17&19) with washer (I & J) and bolt (M) using allen key (S).
Locate all screws as shown ,then fasten tightly.

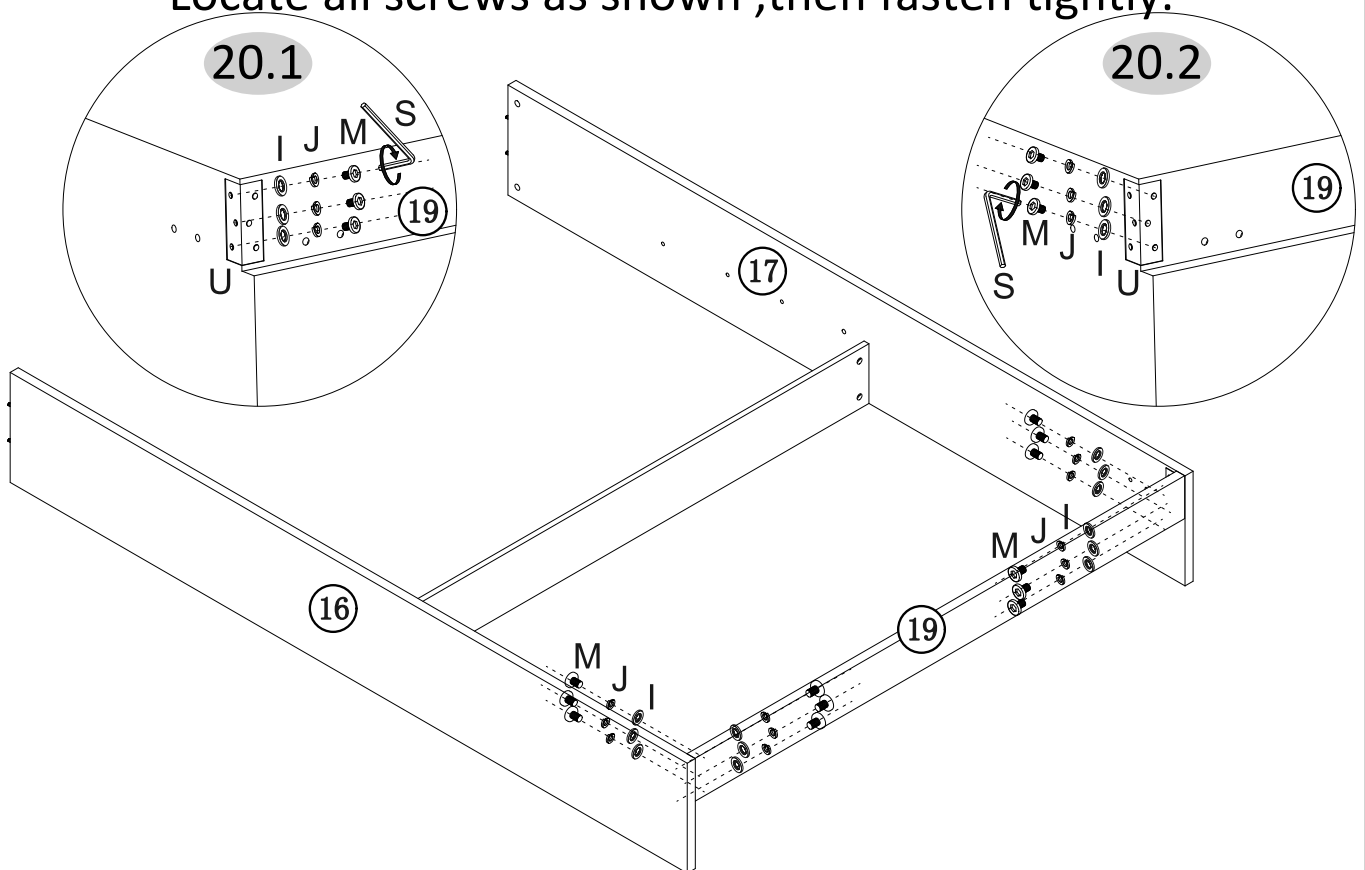

STEP21 : Fix angle iron(W) to panel (16&17&19) with washer (I & J) and bolt (M) using allen key (S).

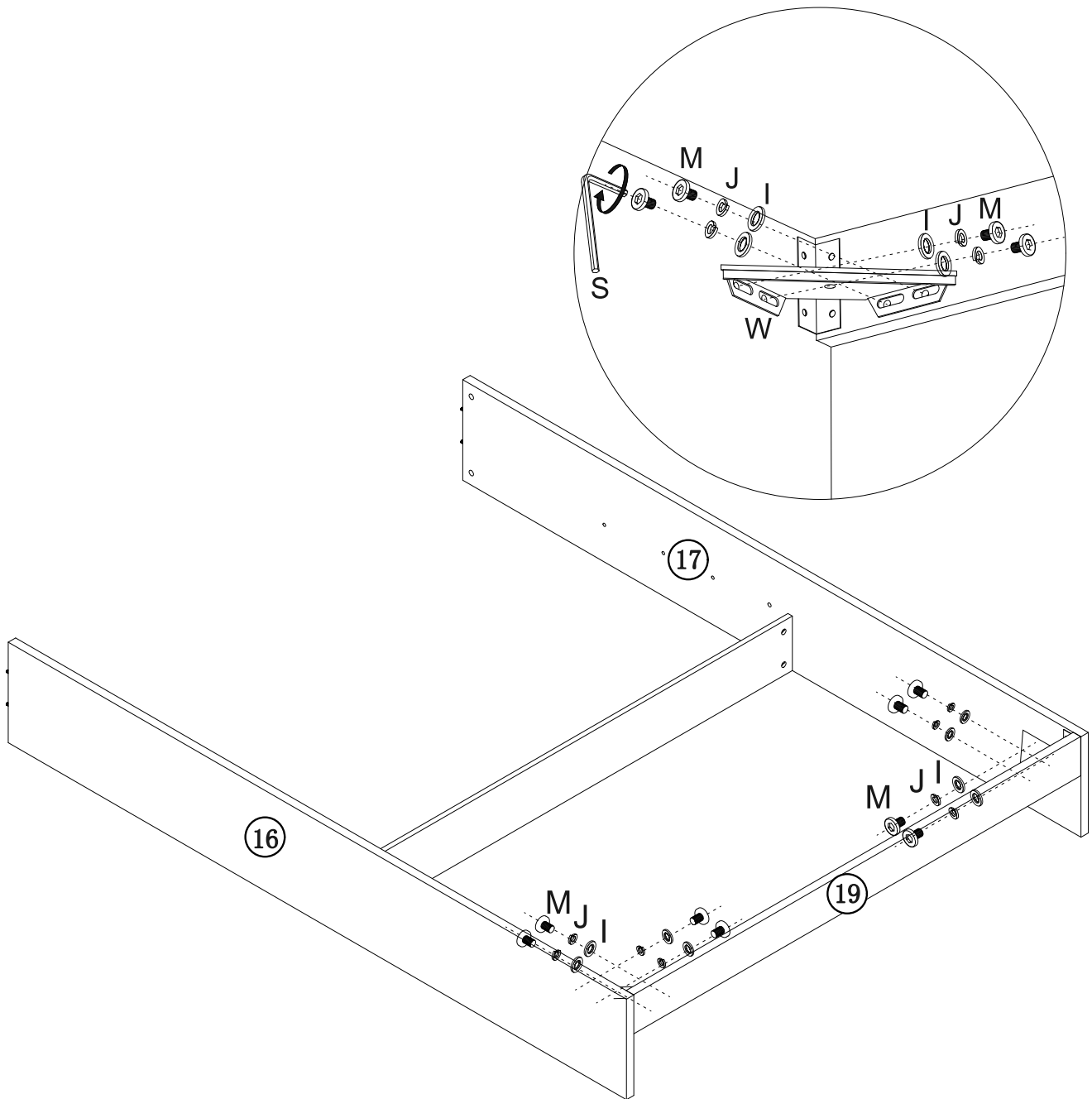

STEP22: Insert nut (R) to panel (16&17).

Attach headboard to panel (16&17) with washer (L& K) and bolt (Q) using allen key (T).

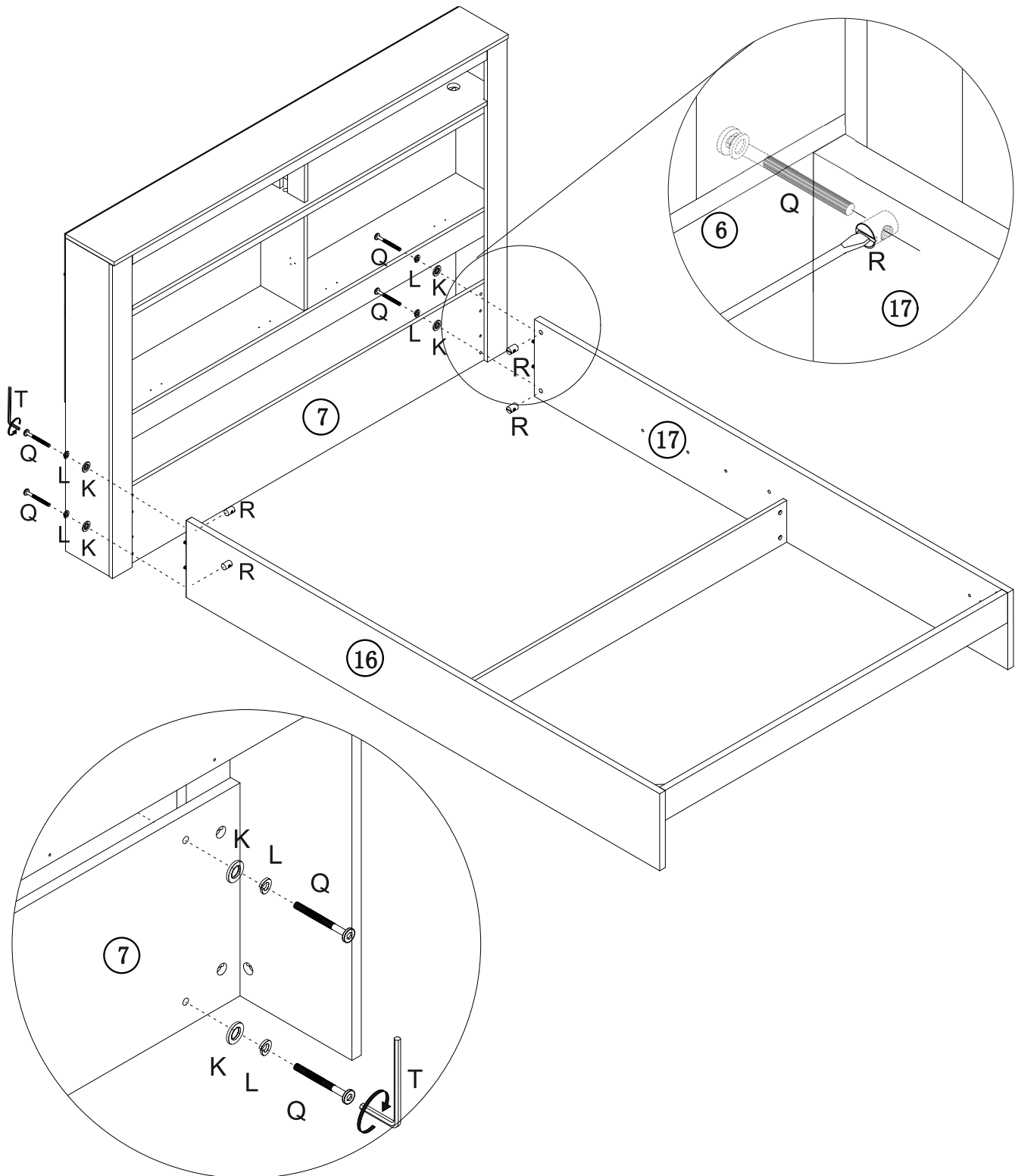

STEP23: Fix hinge (X) to panel (20&21) with screws (E).
Fix lift (Y) to panel (20&21) screws (E).

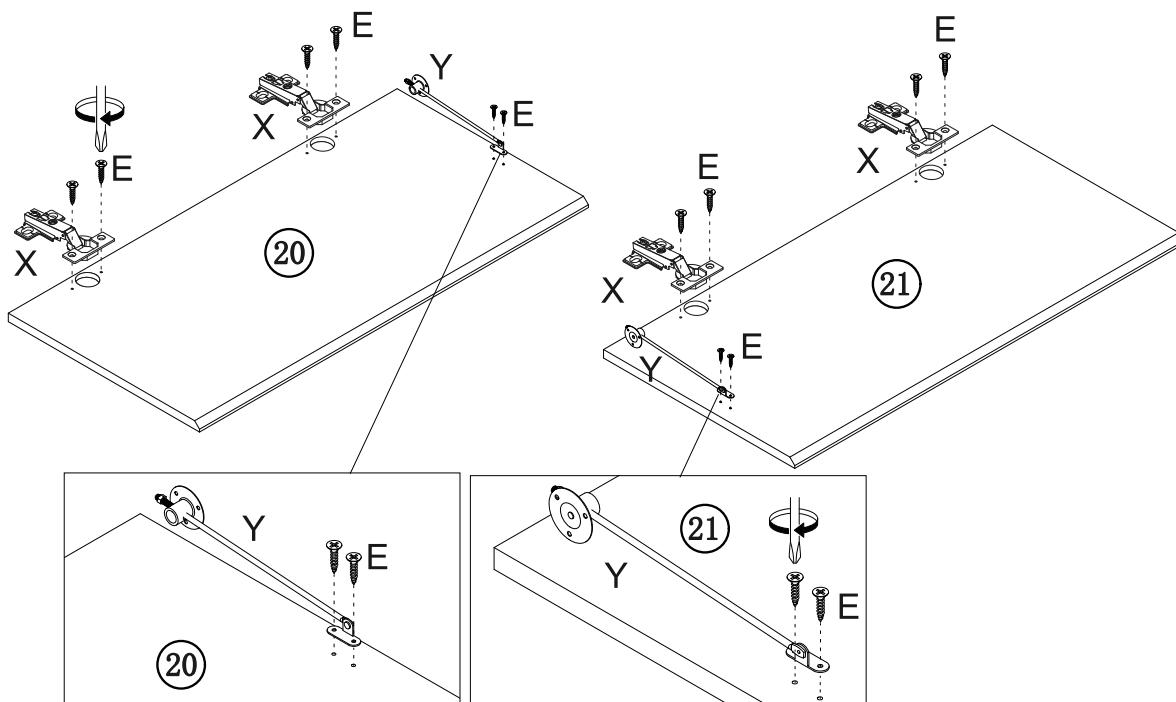

STEP24: Attach panel (20&21) to the body with screws (E).

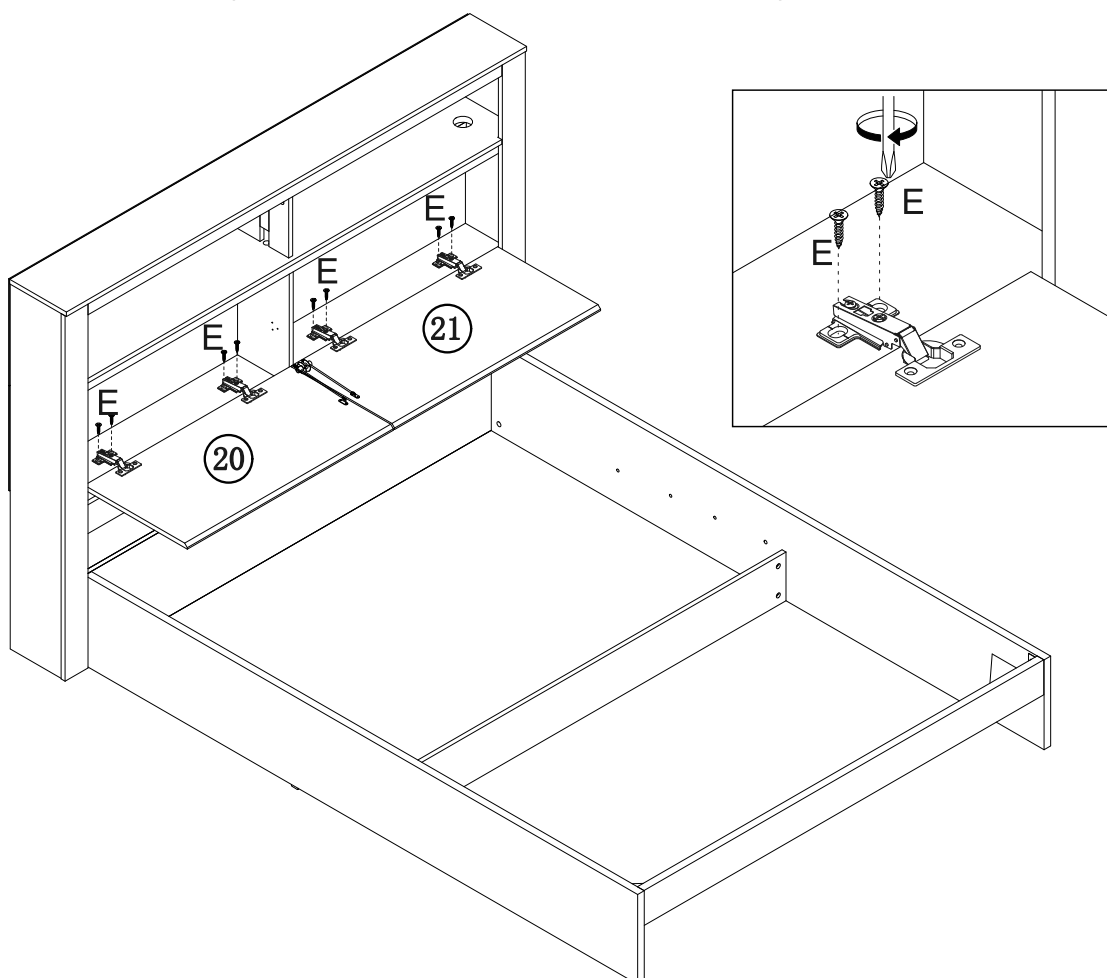

STEP25: Fix lift (Y) to panel (1) with screws (E).

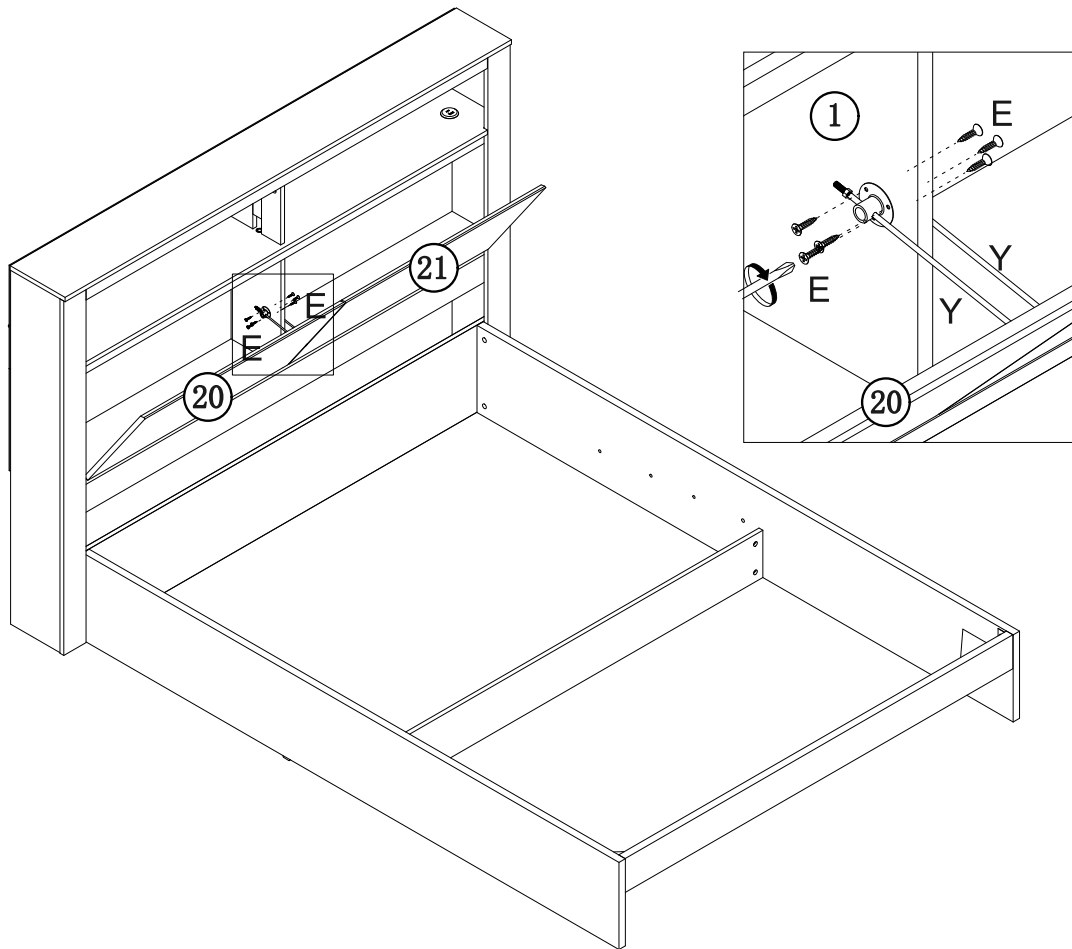

STEP26: Fix lift (AA) to lift (22&23) with nut (V) using wrench (BB).

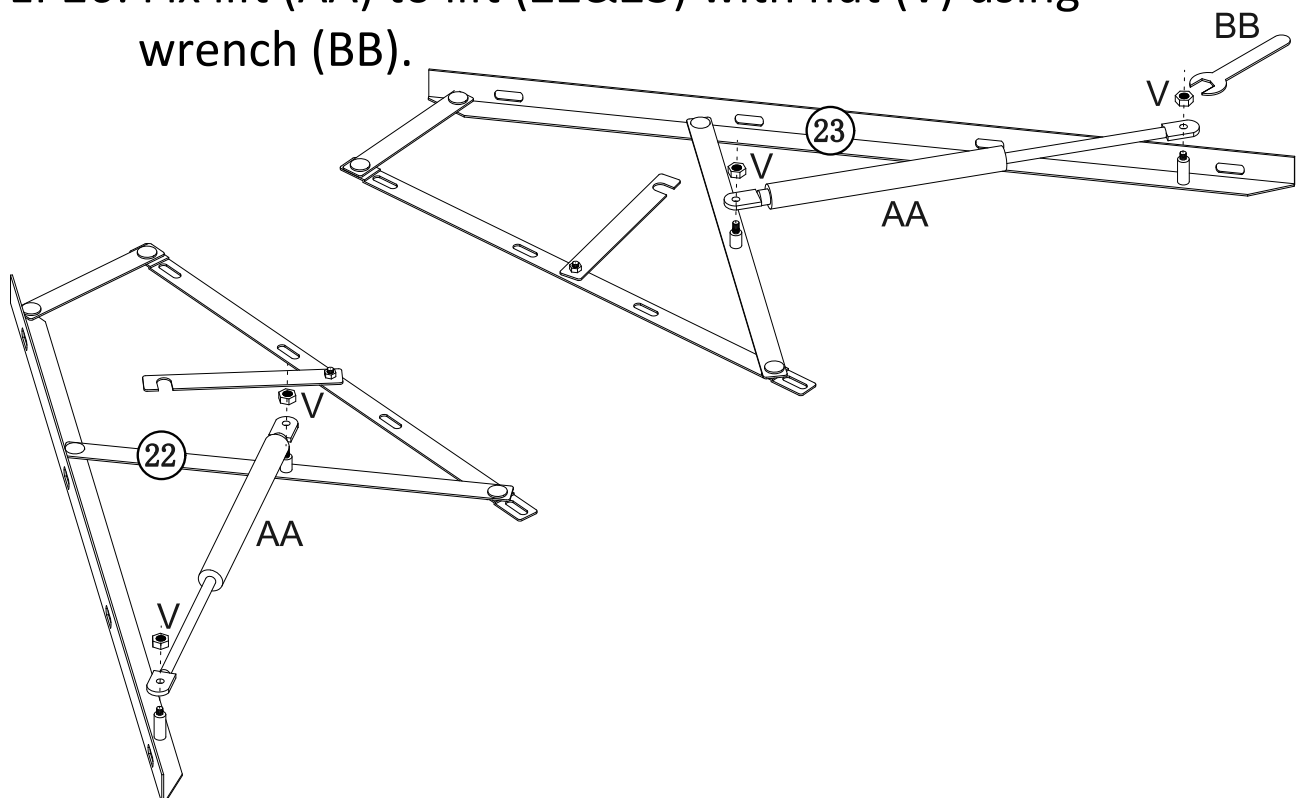

STEP27: Fix lift (22&23) to support panel (24) and side panel (16&17) with washer (L& K) and bolt (N) using allen key (T).

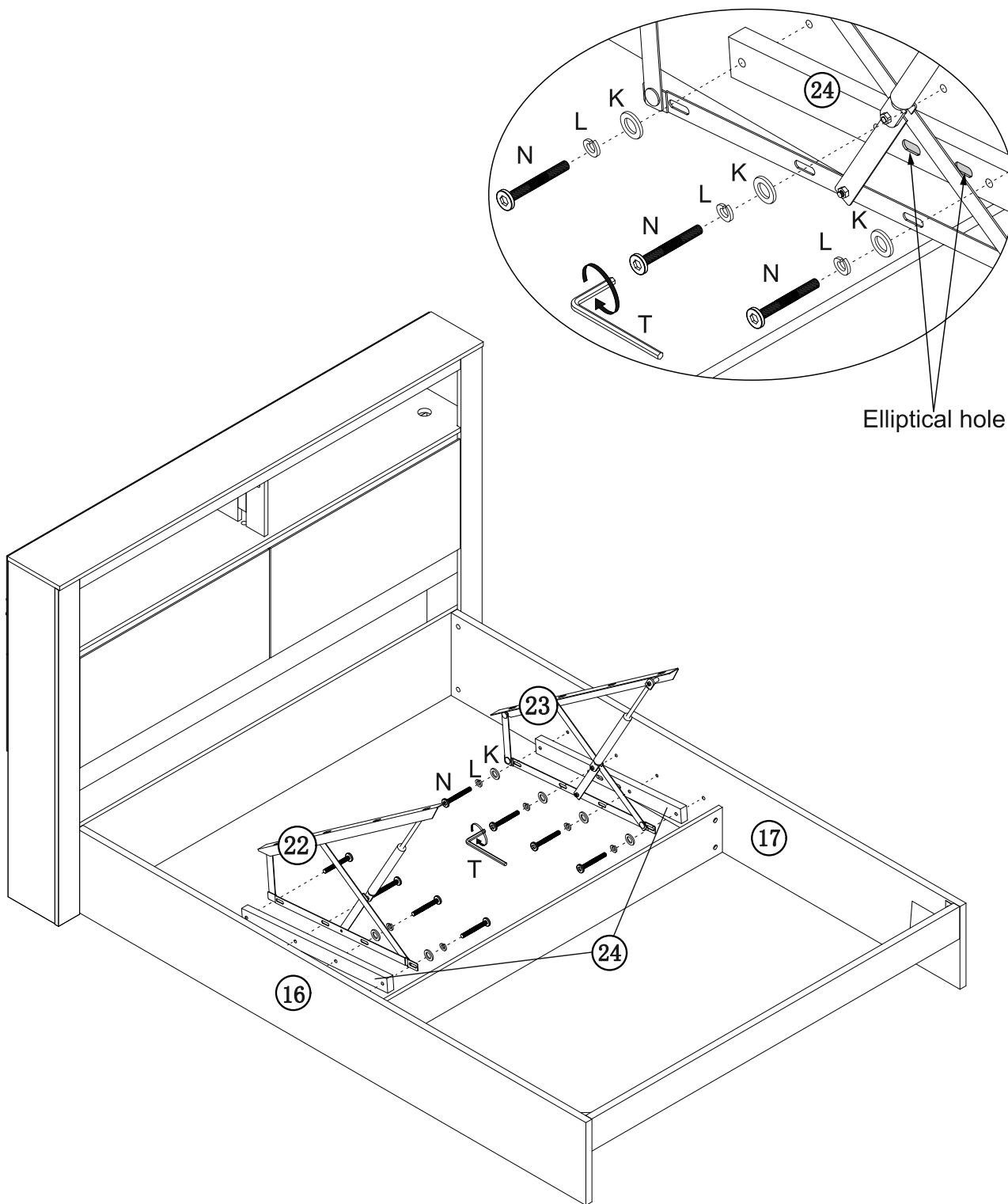

STEP28: Locate (28) to metal part (26&27) with bolt (N).

Fix connector (CC) to metal parts (25), then to metal parts (26).

Fix metal parts (27) to (26&38) with washer (L& K),nut (Z) and bolt (N) using allen key (T).

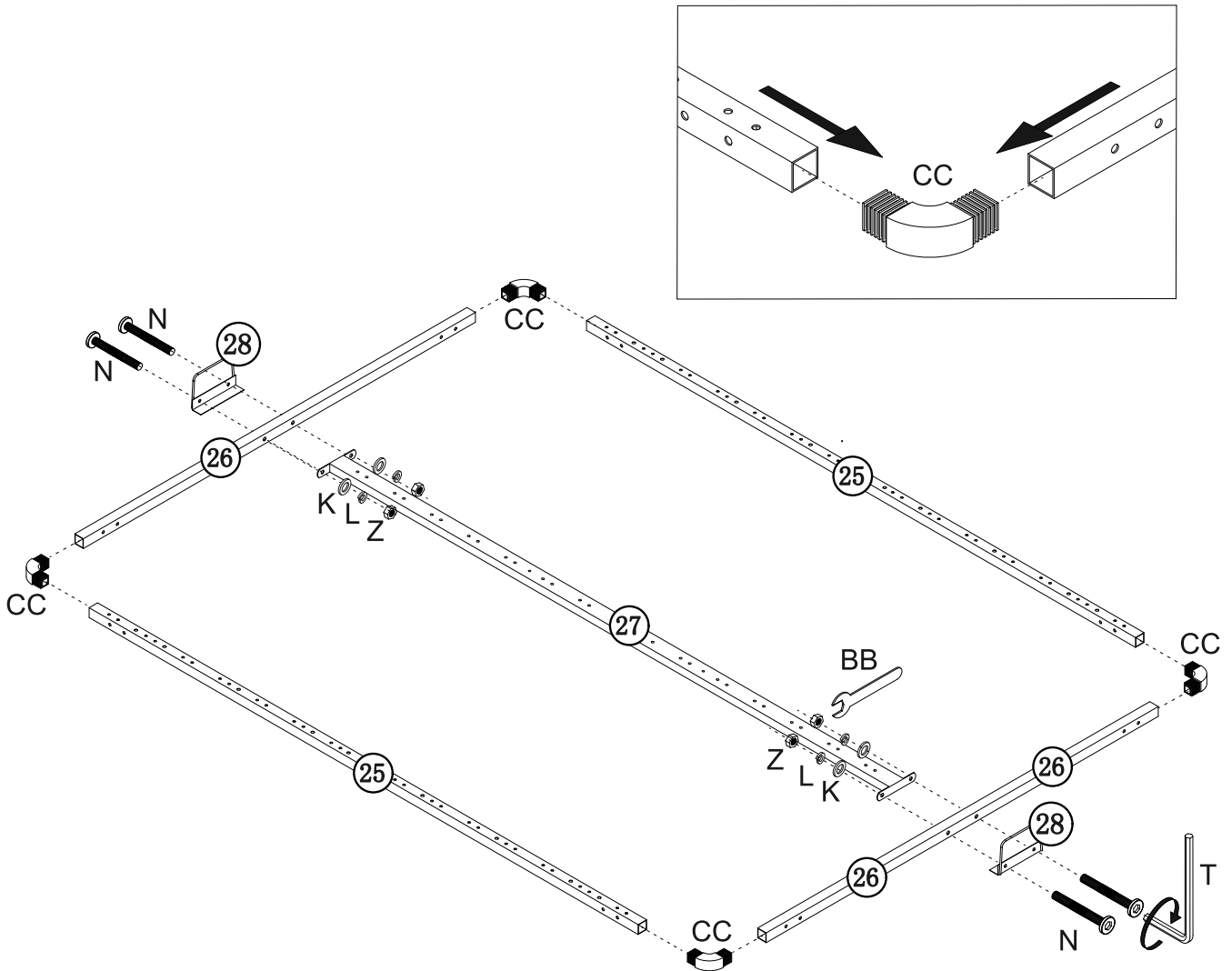

STEP29: Fix angle iron(W) to metal parts (25&26) with washer (L& K), nut (Z) and bolt (N) using wrench(BB) and allen key (T).

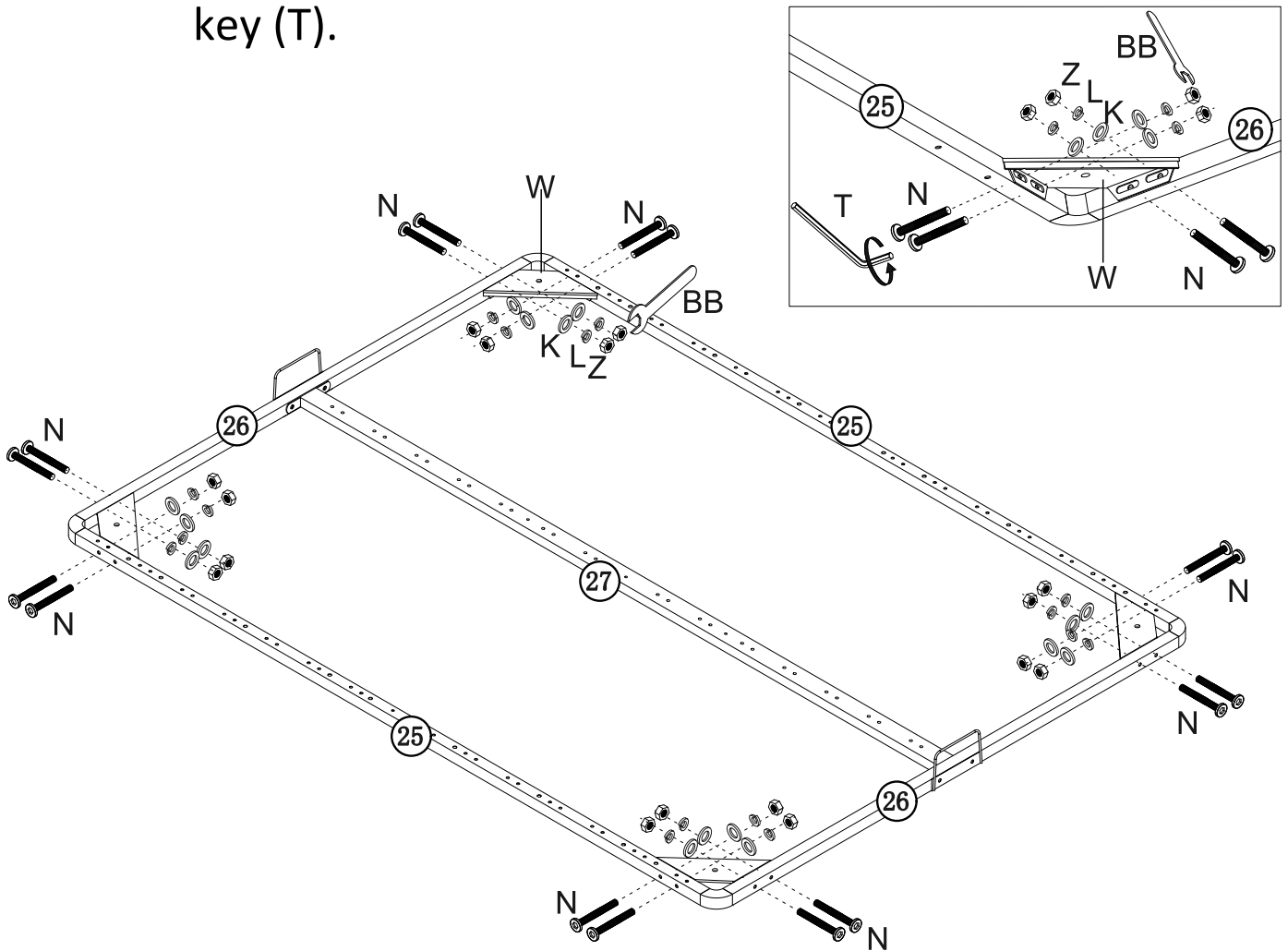

STEP30: Connect slat (29) with metal parts (DD & EE).

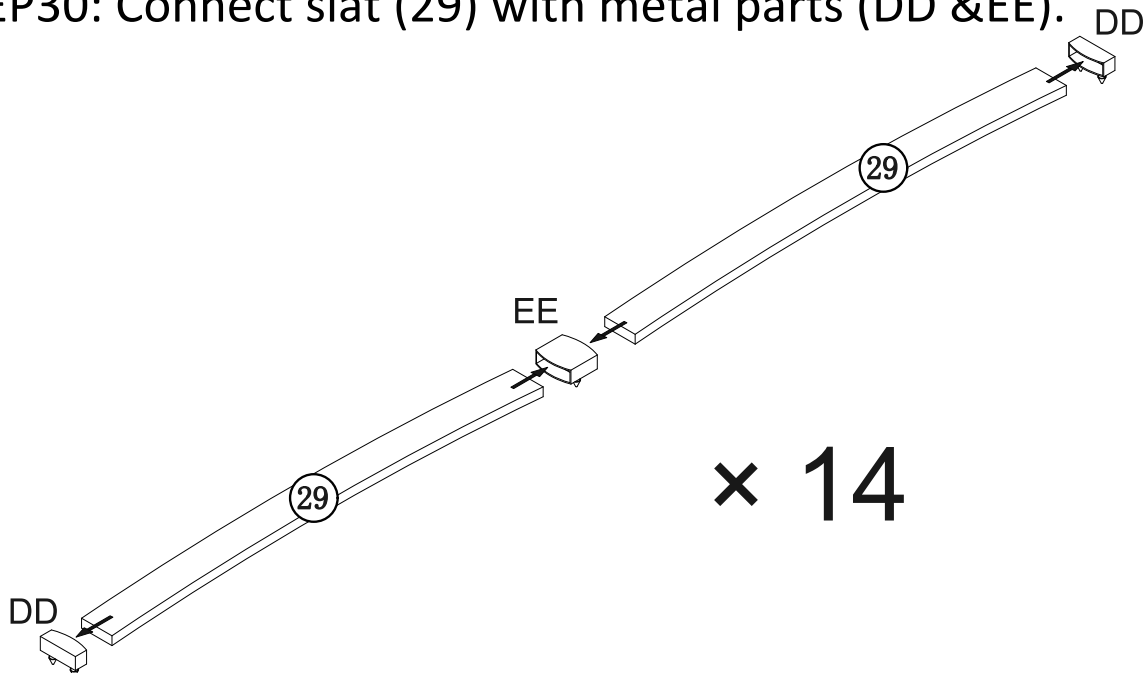

STEP31: Fix slat to metal frame.

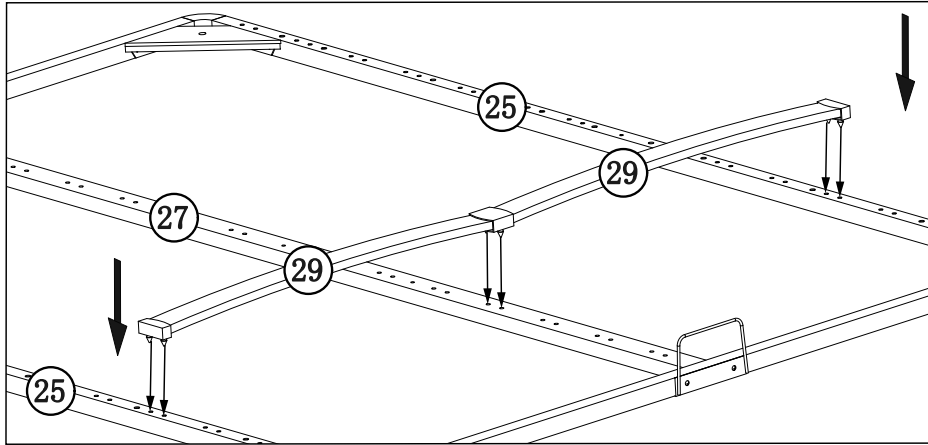

× 14

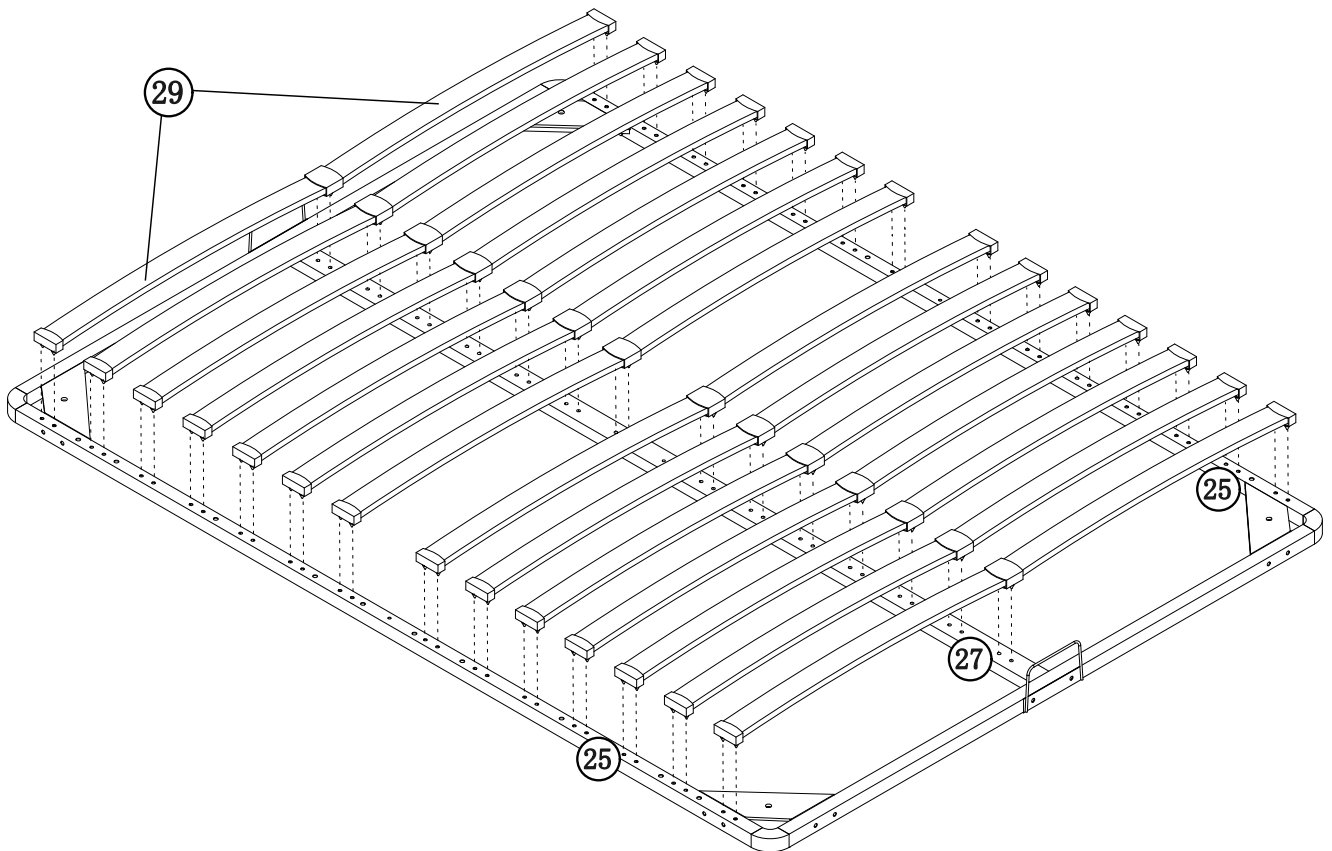

STEP32: Fix leg (31) to metal parts (27&25) with washer (L& K) and bolt (N) using allen key (T).

Fix metal parts (30) to metal frame with washer (I& J), bolt (P) using allen key (S).

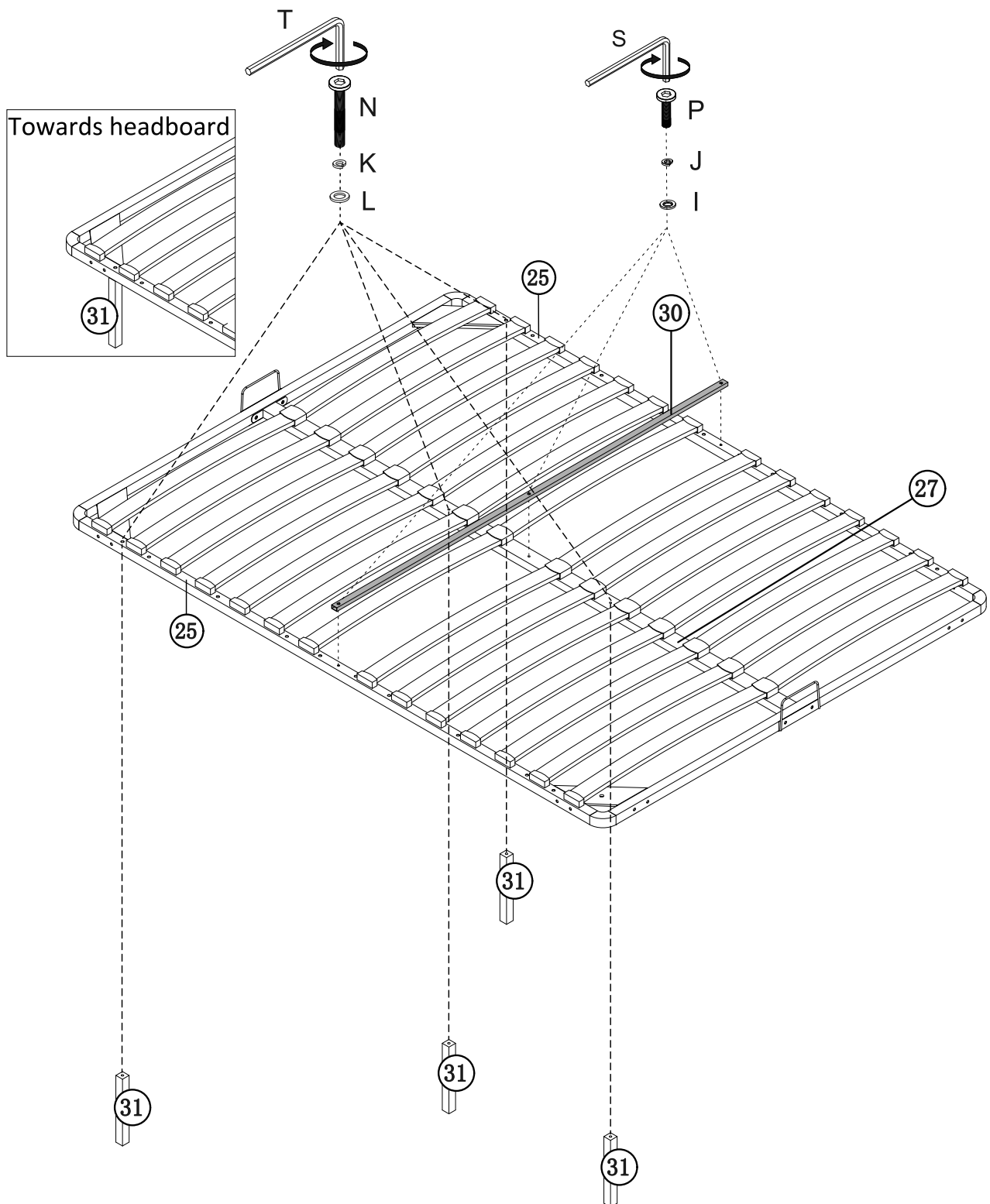

STEP33: Fix metal frame to lift (21&22) with washer (L& K), nut (Z) and bolt (N) using wrench(BB) and allen key (T).

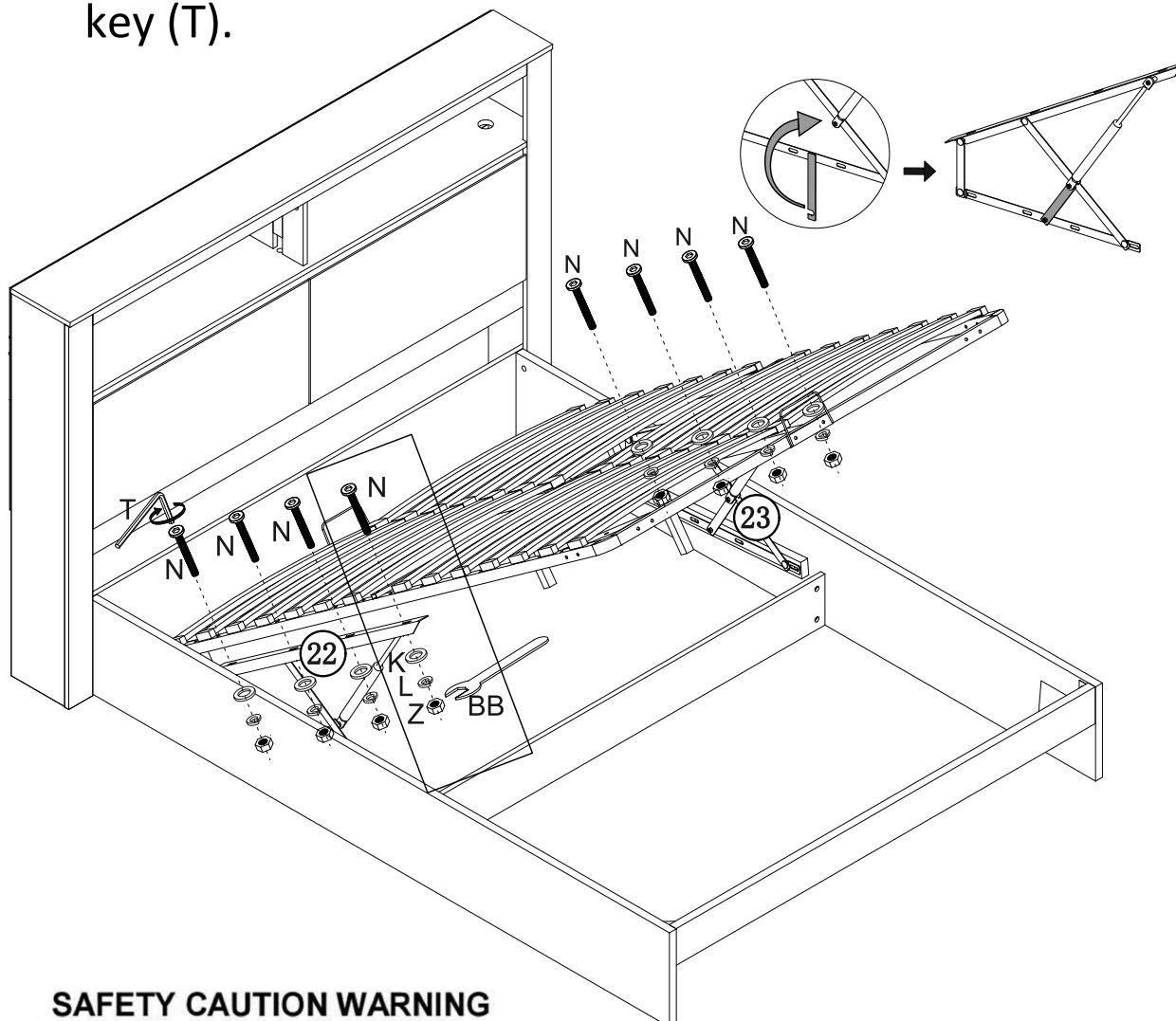

SAFETY CAUTION WARNING

Please always lock the safety lock mechanism while the bed base is in lifting position.
Unlock it before you want to put the bed base back into normal position.

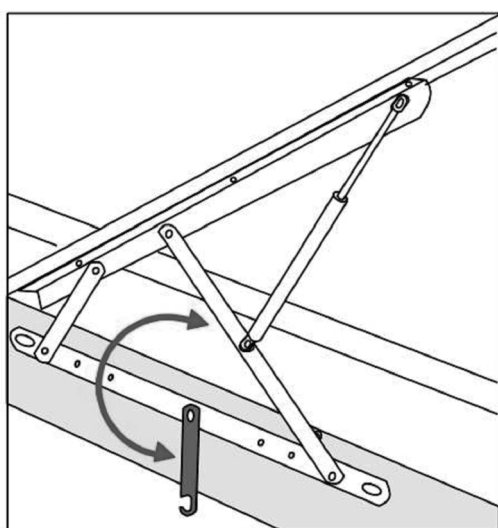

UNLOCK POSITION

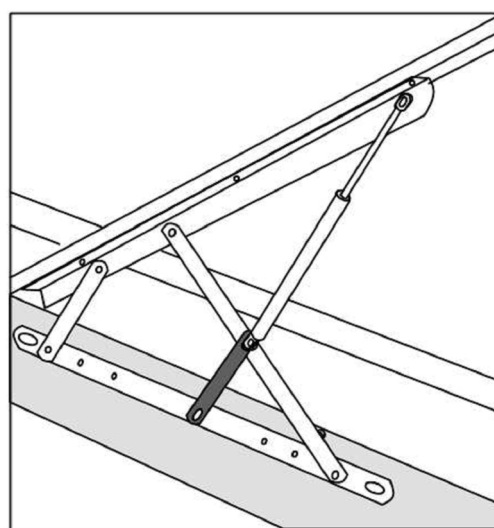

LOCK POSITION

STEP34: Attach panel (32&33&35) to panel (34) with screws (F).

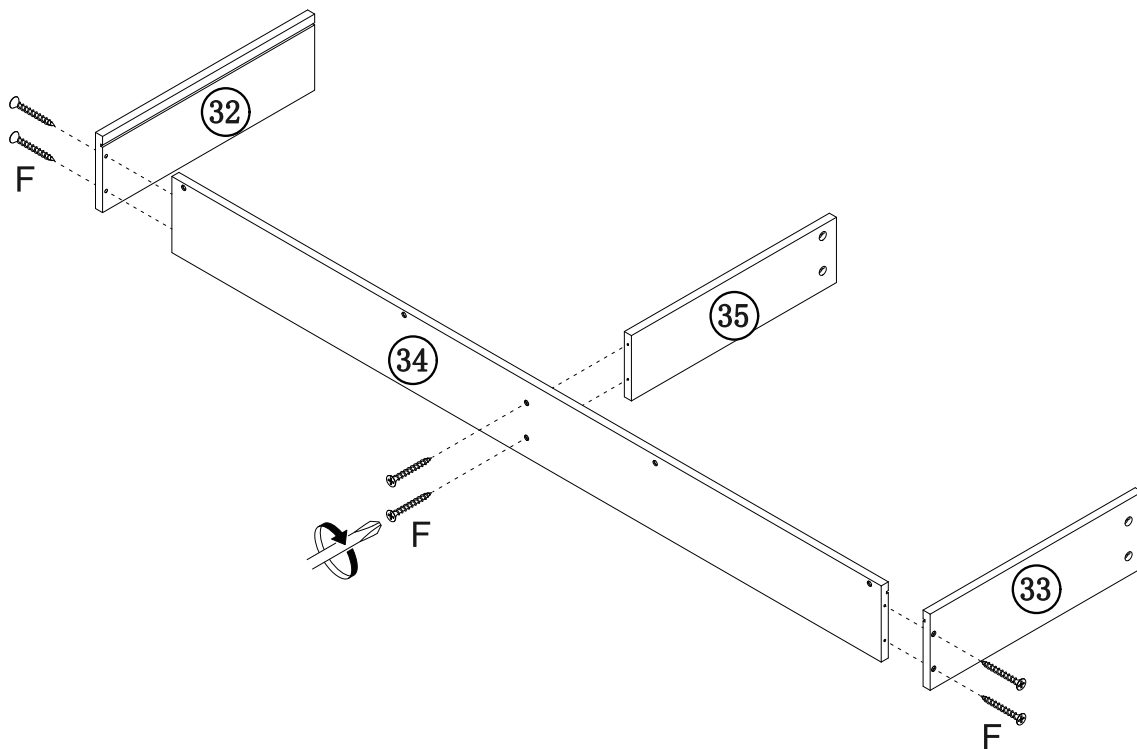

STEP35: Insert drawer base (36) to drawer body.
Attach panel (37&38) to back panel with screws (F).

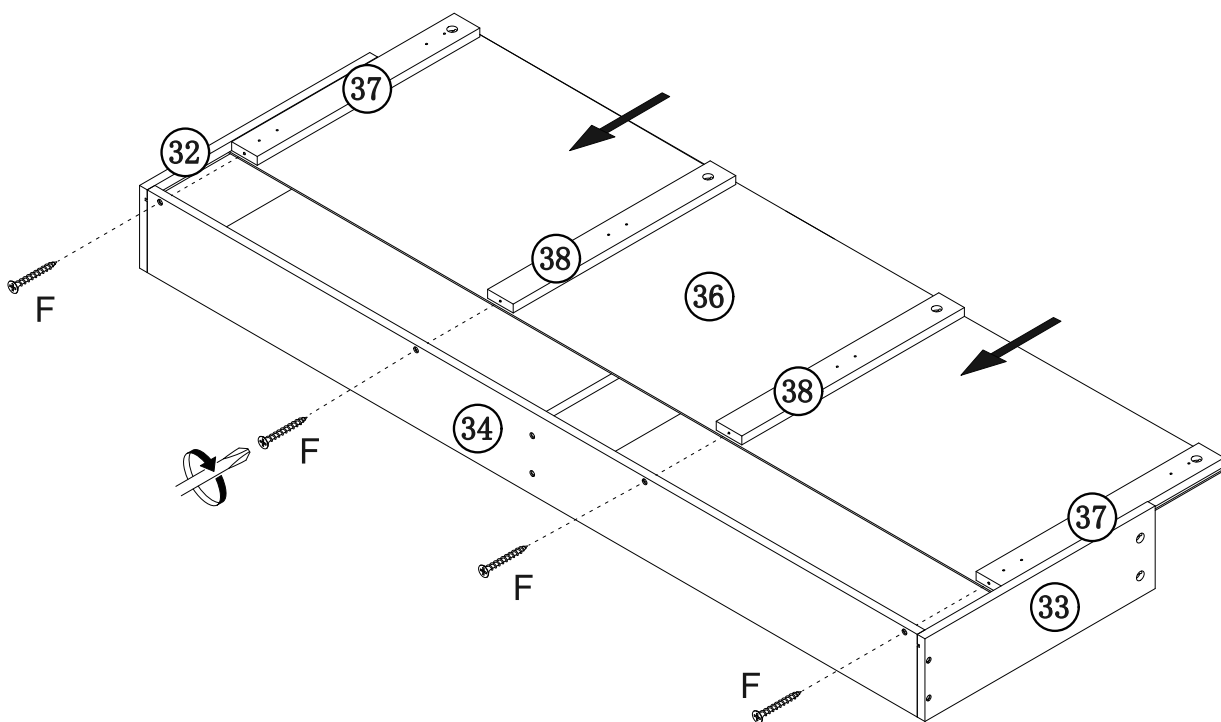

STEP36: Fix cam pin (A) to panel (39).

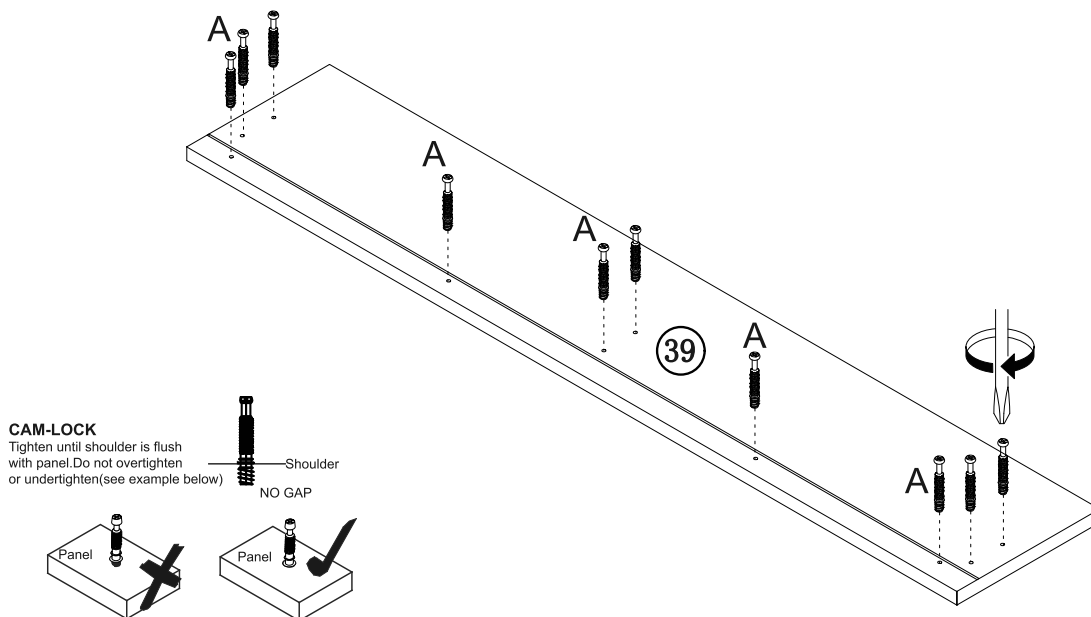

STEP37: Attach panel (39) to the body with cam lock (B).

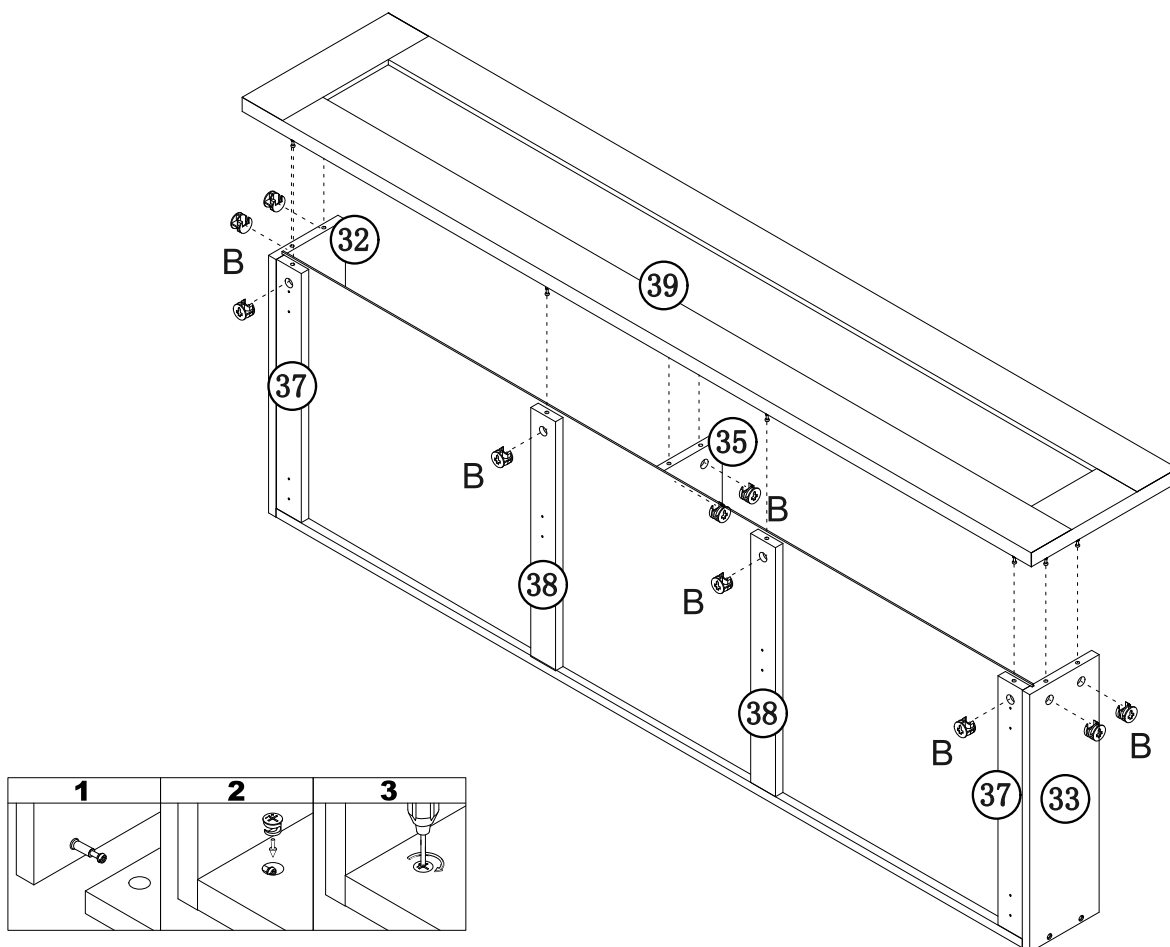

STEP38: Fix wheel (FF) to drawer bottom with screws (E).

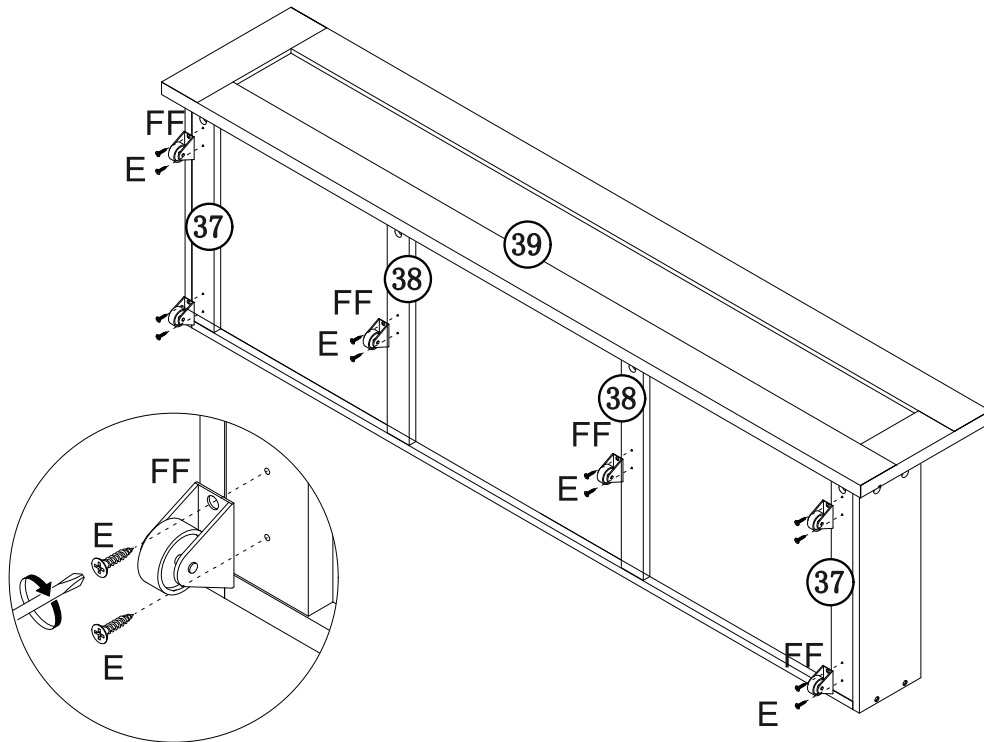

STEP39: Assemble drawer to the body.

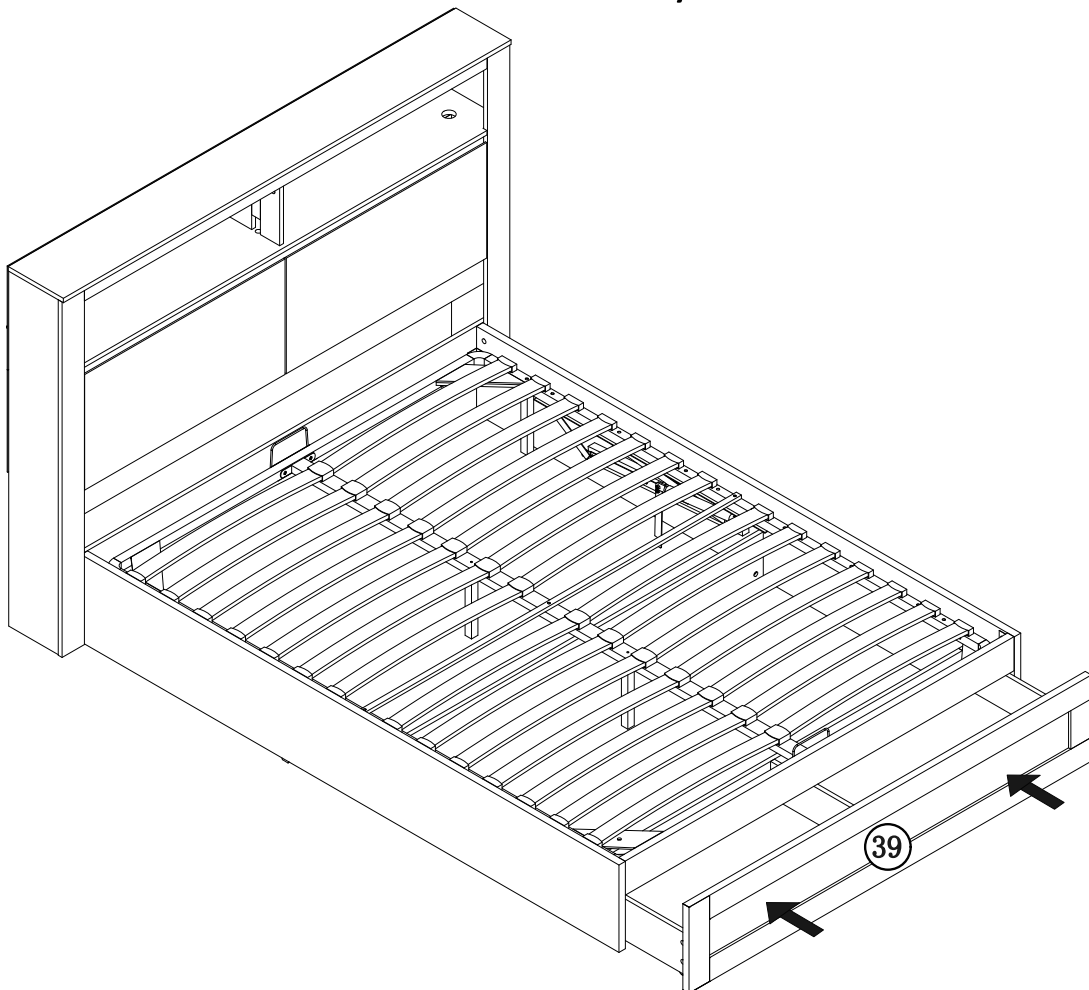

STEP40: Locate USB (JJ) to side holes of headboard and cross shelf panel (3) and back panel (14).
Fix control switch (HH) to middle hole of headboard, then locate wire cross back panel (14).

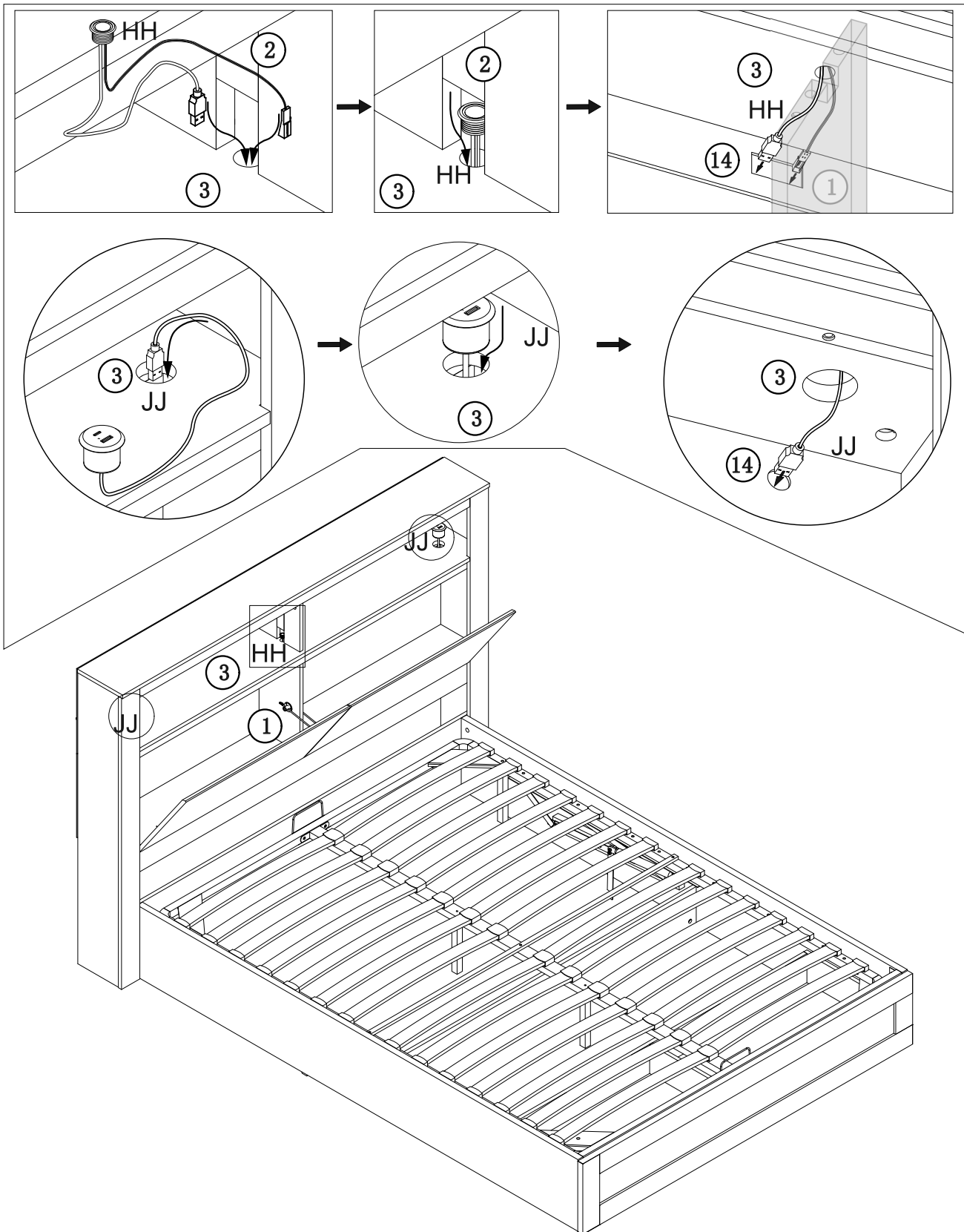

STEP41: Locate led wire cross back panel (14).

Connect wire of USB with (KK).

Connect wire of led and control switch with cable box (II).

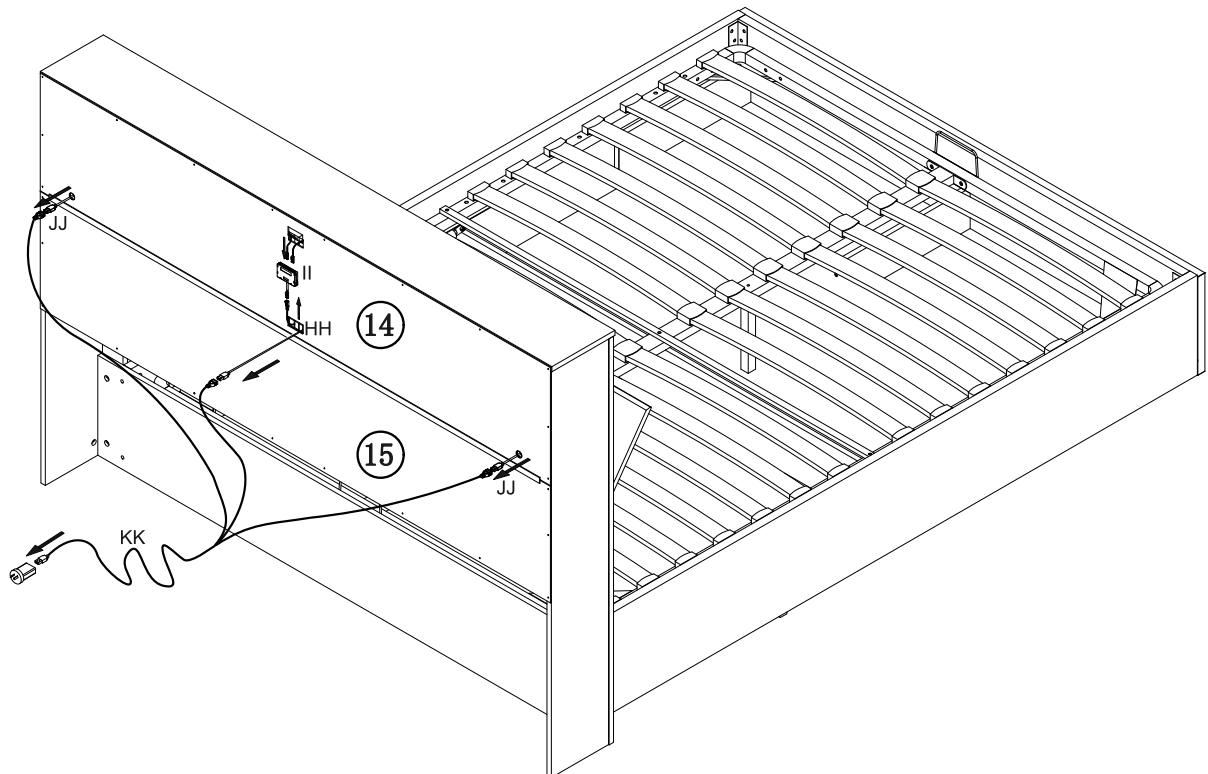
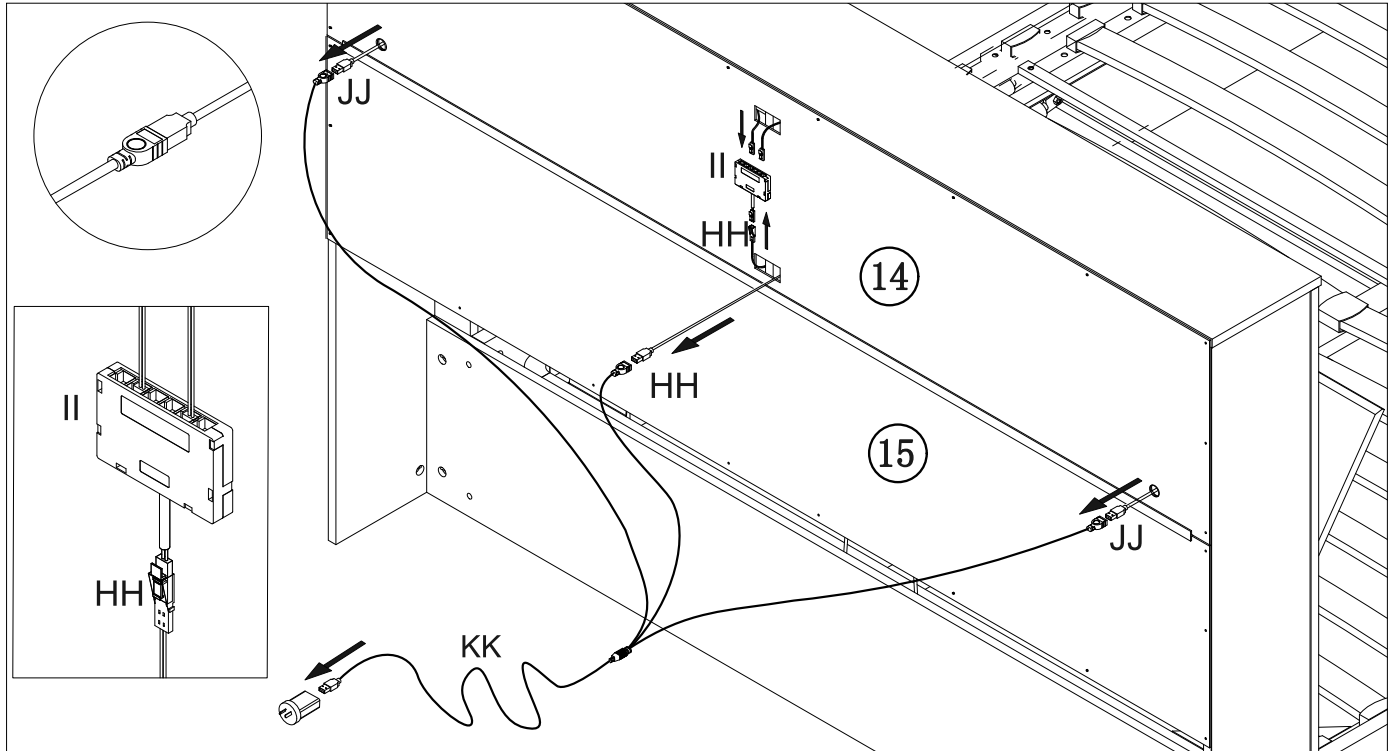

Assembly is complete

WARNING
PINCH HAZARD: BEWARE OF YOUR FINGERS WHEN LIFTING
AND LOWERING THE MECHANISM

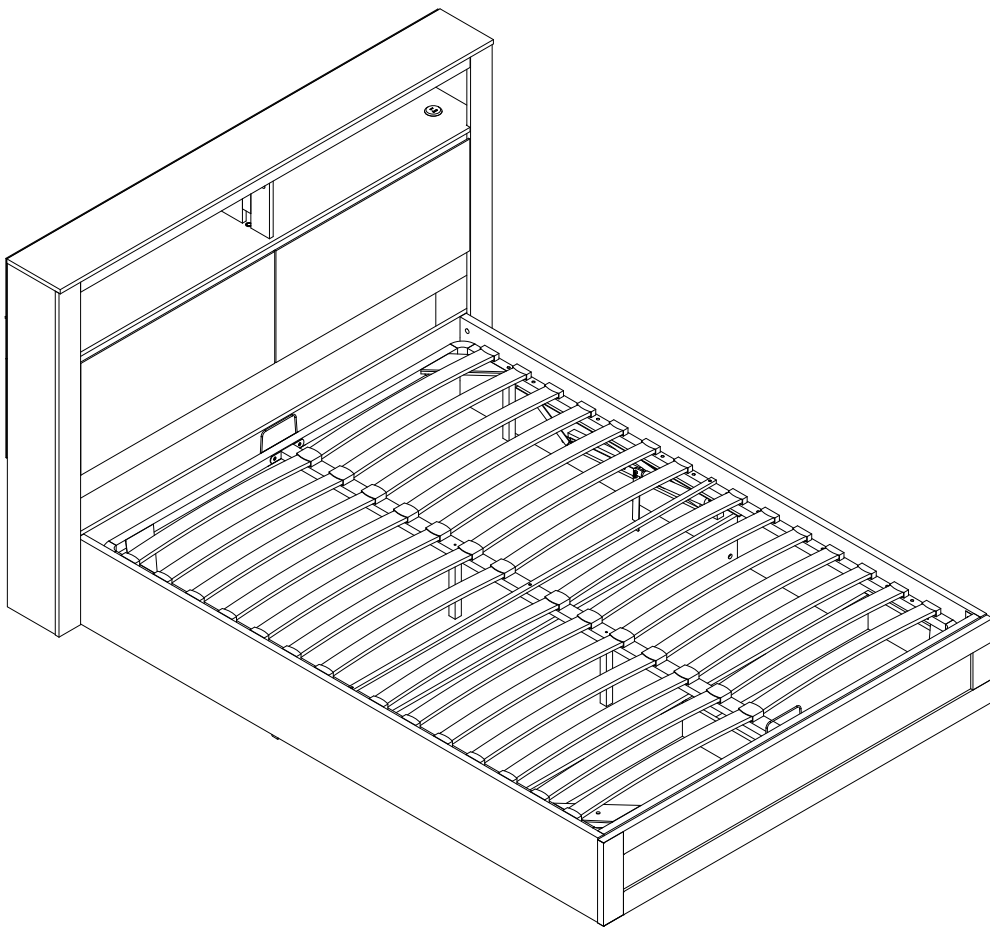

CAUTION:
ALWAYS LIFT YOUR BED WHEN MOVING/RELOCATING - Do
NOT DRAG. DRAGGING CAN CAUSE THE CENTRE SUPPORT
LEGS TO BEND/BREAK

General Product Care

To protect your furniture, we suggest the following:

- Avoid placing your furniture in direct sunlight.
- Do not place furniture directly under windows.
- Do not place sharp materials (knife, fork, etc.) directly onto your furniture as sharp material may scrape and damage the finish.
- Do not place material with high temperature directly onto the surface of your furniture.
- Clean up spills quickly. Water left over a prolonged period of time may cause damage. Alcohol, perfume, nail polishes, aftershave and some medication may cause severe finish damage if not cleaned immediately.
- Use a clean, soft, dry, lint free absorbent cloth to clean your furniture. Do not use any detergent as they may contain ingredients that may react and damage the finish.